

Wolfgang Amadeus  
**MOZART**

---

**Requiem**

KV 626

Soli (SATB), Coro (SATB)  
2 Corni di bassetto, 2 Fagotti  
2 Clarini, 3 Tromboni, Timpani  
2 Violini, Viola e Bassi  
(Violoncello / Contrabbasso, Organo)

herausgegeben und eingerichtet von  
edited and revised by  
Richard Maunder

Gemeinschaftsausgabe mit Oxford University Press  
Published in collaboration with Oxford University Press

Klavierauszug / Vocal score



---

Carus 40.630/03

# Introitus

## Requiem aeternam

Wolfgang Amadeus Mozart  
1756–1791

Corni di  
Bassetti  
Fagotti  
Clarini  
Timpani  
Tromboni  
Arch. Organo

Adagio

Musical score for the beginning of the Requiem aeternam, featuring woodwinds and strings. The tempo is Adagio. The score includes a piano (p) dynamic marking and a triplet of eighth notes in the upper woodwind part.

5  
Soprano  
Alto  
Tenore  
Basso

Vocal staves for Soprano, Alto, Tenor, and Bass. The lyrics are: qui-em ae-

Musical score for the vocal ensemble, marked **Tutti f**. The lyrics are: er - - nam do - na e - is - -  
nam do - na e - is Do - -  
- qui - - nam do - na e - is Do - mi-ne,  
- ter - nam do - na,

Piano accompaniment for the vocal ensemble, continuing the musical texture.

Do - mi - ne, re - qui - em ae - ter - nam do - na e - is Do - mi - ne:  
 - mi - ne, do - na e - is Do - mi - ne, do - na e - is Do - mi - ne:  
 re - qui - em ae - ter - nam do - na e - is Do - mi - ne, e - is Do - mi - ne:  
 do - na e - is Do - mi - ne, re - qui - em ae - ter - nam do - na e - is Do - mi - ne:

12

et lux per - pe - tu - a, et lux per - pe - tu - a lu -  
 et lux per - pe - tu - a, et lux per - pe - tu - a  
 et lux per - pe - tu - a, et lux per - pe -  
 et lux per - pe - tu - a, et lux per - r at,

15

lu - ce - at e  
 lu - ce - at  
 lu -  
 is.  
 is.

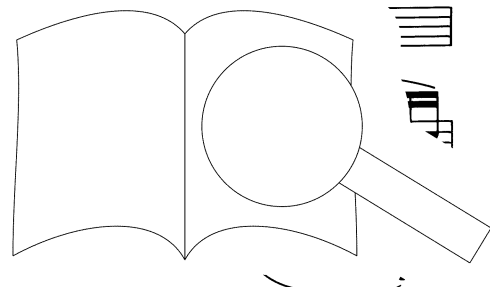

21

Solo

Te de - cet hy - mnus De - us in Si - on,

21

24

et ti - bi red - de - tur vo - tum in Je - ru - sa - lem:

Ex - au - di, ex -

24

27

Tutti *f*

Ex - au - di, ex - au - di, ex - au - di, ex - au - di, ex - au - di o - ra - ti - o - nem me - am, ad te, ad

o - ra - ti - o - nem me - am, ad

di, ex - au - di o - ra - ti - o - nem me - am, ad

27

PROBE PARTITUR

Ausgabequalität gegenüber Original evtl. gemindert • Evaluation Copy - Quality may be reduced • Carus-Verlag

ad te o - mnis ca - ro ve - - ni - et.

ad te o - mnis, o - mnis ca - ro ve - ni - et.

te o - - mnis, - o - mnis ca - ro ve - ni - et.

te, ad te o - mnis, o - mnis ca - ro ve - ni et.

Do - na, do

Re

Re

Do - na, do - is - Do - mi-ne, do - na,

Do - mi-ne, a e - - is, - re - - qui - em ae - ter -

ani - nam do - na, do - is

PROBENPARTITUR

Ausgabequalität gegenüber Original evtl. gemindert • Evaluation Copy - Quality may be reduced • Carus-Verlag

do - na e - is, re - qui - em ae - ter - nam, ae - ter -  
 - nam do - na e - is, Do - mi - ne, do - na e - is, do - na  
 e - is, do - na e - is, do - na, do -  
 Do - mi - ne, do - na, do - na e - is, do - na

- nam, ae - ter - nam: et lux per - pe - tu - a, et  
 e - is, do - na: et lux per  
 na, do - na: et et lux per -  
 e - is, do - na: et lux per -

lu -  
 pe - tu - a et lux per - pe - tu - a lu - ce - at e - is.  
 ce - at e - is, et lux per - pe - tu - a lu - ce - at e - is.  
 ce - at e - is, et lux per - p

PROBEKOPPIERT  
 Ausgabegüte gegenüber Original evtl. gemindert • Evaluation Copy - Quality may be reduced • Carus-Verlag

# Kyrie

Allegro

Chri - ste e - le -

Ky - ri - e e - le - i - son, e - le -

Allegro

Ky - ri - e e - le - i - son,

i - son.

Chri - st

- i - son, e - le - i - son

ri -

- son, e - le - i - son, e - le -

ri - e e - le - i - son, e -

i - son, e - le

i - son, e - le - i - son.

- i - son, e - le - - i - son. Chri - ste e -

le - - - i - son, e - le - - i - son,

Ky - - ri - e e - le - - i -

i - son, e -

le

e - le - - i - son, e - le - i

son, e - le -

le - - i - son, e - le -

le - i - son,

son.

le - - i - son, e - le - -

le - - n. Ky - ri - e e - lei - son, e - lei - son,

- i - son, e - l - son.

- i - son. Chr

PROBEPARTITUR  
 Ausgabqualität gegenüber Original evtl. gemindert • Evaluation Copy - Quality may be reduced • Carus-Verlag

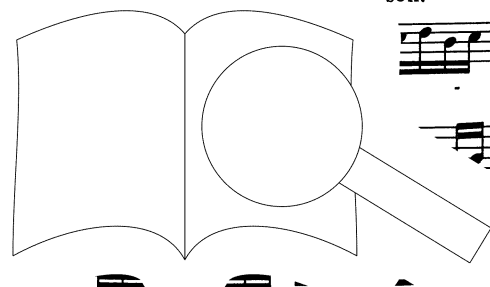



19

i - son. Chri - ste e - lei

e - le i - son. Chri - ste e - le

8 Ky - ri - e e - le - i - son, e -

i - son.

19

22

son.

i - son.

8 le i -

Ky e - le i -

22

25

le

son,

Ky - ri -

i -

i -

25

PROBENPARTEI

Ausgabequalität gegenüber Original evtl. gemindert • Evaluation Copy - Quality may be reduced • Carus-Verlag

e e - le - i - son, e - le - i  
 son, e - lei - son, e - le - i - son.  
 son. Chri - ste e - le - i - son. Chri - ste e -  
 i - son. Ky - ri - e e - le - i -

son, e - le - i - son, e - le - i - son.  
 Ky - i -  
 le - son.  
 son, e - le Chri - ste e -

e - le son,  
 son, Chri - ste e -  
 Chri - ste e - le i -  
 i - son,  
 i - son,

PROBEPARTITUR  
 Ausgabequalität gegenüber Original evtl. gemindert • Evaluation Copy - Quality may be reduced • Carus-Verlag

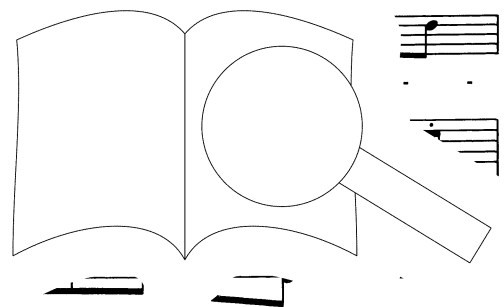

Chri - ste e - le - i - son, e - le -  
 le - i - son, e - le - i - son. Ky - ri -  
 son, e - le - i - son, e - le - i - son. Ky - ri -  
 son.

Chri - ste e - le -

- i - son. Chri - ste e -  
 e e - lei - son, e - le -  
 e, Ky - ri - e e - le - i -  
 - i - son. Ky - ri - e e

(38)

i - son. i - son, e - le - i - son, e - le - i -  
 Ky - ri - e e - le - i - son. Ky - ri -  
 - i - son le - i -  
 i -

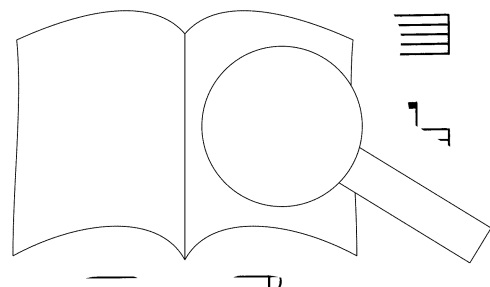

PROBE  
 Ausgabequalität gegenüber Original evtl. gemindert • Evaluation Copy - Quality may be reduced • Carus-Verlag

son. Chri - ste e - le -

e e - le - i - son, e - le - i - son.

son, e - le - i - son, e - le - i -

Chri - ste e - le - i - son, e - le - i -

- i - son. Chri - ste e - le -

Chri - ste e - le - i - son, e.

son, e - le - i - son, e - le - i Ky - ri -

son, e - le - i - son, i - son, e - le -

Adagio

- i - son, e -

Ky - ri - e e - le - i - son.

e

Ky - ri - e e - le - i - son.

- son. Ky - ri - e

- i - son. Ky - ri -

Adagio

PROBEPARTITUR

Ausgabequalität gegenüber Original evtl. gemindert • Evaluation Copy - Quality may be reduced • Carus-Verlag

# Sequenz

## Dies irae

Allegro assai

Tutti *f*

Di - - es i - rae, di - - es

Di - - es i - rae, di - - es

Di - - es i - rae, di - - es

Di - - es i - rae, di - - es

Allegro assai

il - la, sol-vet sae - clum in fa - vil - la: te - ste

il - la, sol-vet sae - clum in fa - vil - la: Si -

il - la, sol-vet sae - clum in fa - vil - la: cum Si -

il - la, sol-vet sae - clum in fa - vil - vid cum Si -

byl - la. Quan - - - tus

byl - la. Quan - - - tus

byl - tus

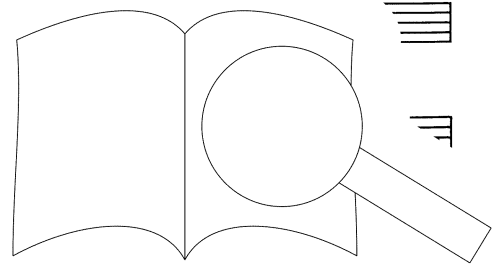

11

tre - mor est fu - tu - - rus, quan - - do  
 tre - mor est fu - tu - - rus, quan - - do  
 8 quan - - tus tre - mor est fu - tu - rus,  
 tre - mor est fu - tu - - rus, quan - - do

14

ju - dex est ven - tu - - rus, cun  
 ju - dex est ven - tu - - rus,  
 8 quan - - do ju - dex est cun - cta  
 ju - dex est ven - tu - - rus, cta

17

stri - cte su - - rus!  
 stri - cus - su - - rus!  
 stri dis - cus - su - - rus!  
 dis - cus - su

PROBEPARTITUR  
 Ausgabqualität gegenüber Original evtl. gemindert • Evaluation Copy - Quality may be reduced • Carus-Verlag

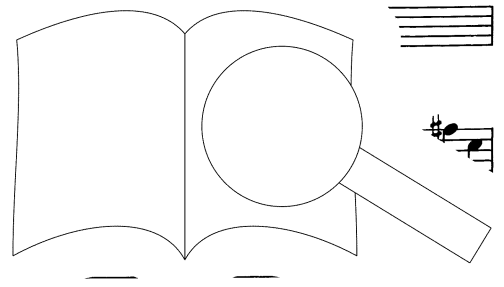

Di - es

Di - es

Di - es

Di - es

i - rae, di - es il - la, sol - vet sae

i - rae, di - es il - la, sol - vet sae

i - rae, di - es il - la, sol - vet sae

i - rae, di - es il - la, sol - vet sae

clum in fa -

clum in fa -

vil - la: te - cum Si - byl - la.

vil - la: id cum Si - byl - la.

vil - Da - vid cum Si - byl - la

te - ste Da - vid cum

PROBEPARTITUR

Ausgabequalität gegenüber Original evtl. gemindert • Evaluation Copy - Quality may be reduced • Carus-Verlag

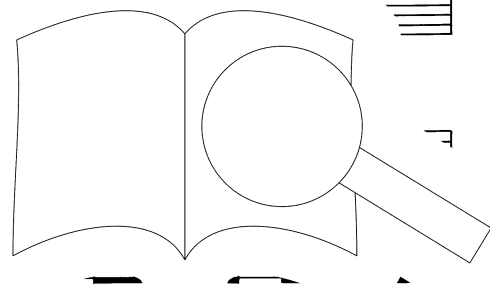

Quan - - - tus tre - mor est fu -

Quan - - - tus tre - mor est fu -

Quan - - - tus tre - mor est fu -

Quan - - - tus tre - mor est fu -

tu - rus, quan - - do ju -

tu - rus, quan - - do es ven -

tu - rus, quan - - do ju - est ven -

tu - rus, quan - - do ex est ven -

tu - r' cta stri - cte

tu - n - cta stri - cte

tu - cun - cta

tu - cun - cta

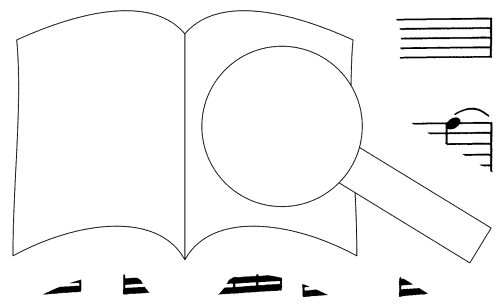

PROBE PARTITUR

Ausgabequalität gegenüber Original evtl. gemindert • Evaluation Copy - Quality may be reduced • Carus-Verlag



39

dis - cus - su - rus! Di - es  
 dis - cus - su - rus! Di - es  
 dis - cus - su - rus! Di - es  
 dis - cus - su - rus! Quan - tus tre - mor\_ est\_ fu - tu - rus,

39

43

i - rae, di - es il - la,  
 i - rae, di - es il - la,  
 i - rae, di - es il - la,  
 tre est fu -

43

46

di di - es il - la,  
 rae, di - es il - la,  
 i - rae, di -

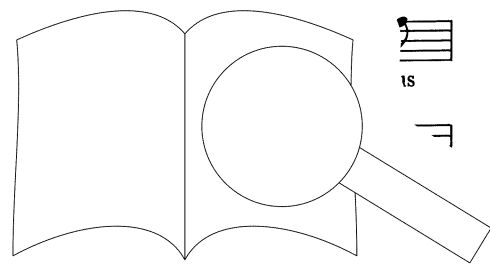

PROBEPARTITUR  
 Ausgabequalität gegenüber Original evtl. gemindert • Evaluation Copy - Quality may be reduced • Carus-Verlag

quan - tus tre - mor est fu -  
 quan - tus tre - mor est fu -  
 quan - tus tre - mor est fu -  
 tre - mor est fu - tu - rus, quan - tus tre - mor est fu -

49

tu - rus, quan-do ju - dex est ven - tu - rus, cun-  
 tu - rus, quan-do ju - dex est ven - tu - rus, - cr - cus -  
 tu - rus, quan-do ju - dex est ven - tu - cte dis - cus -  
 tu - rus, quan-do ju - dex est ven - stri - cte dis - cus -

52

su - rus, - - - cta stri - cte,  
 su - cun - - cta stri - cte,  
 cta

PROBEPARTITUR

Evaluation Copy - Quality may be reduced. Carus-Verlag

Ausgabequalität gegenüber Original evtl. gemindert

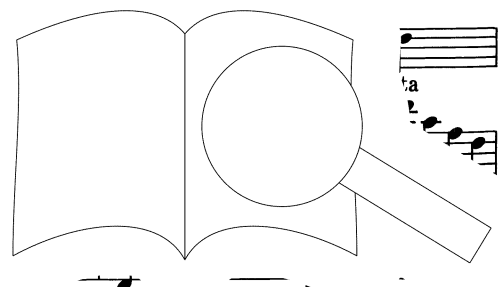

stri - cte dis - cus - su - - rus, cun - - cta

stri - cte dis - cus - su - - rus, cun - - cta

8 stri - cte, stri - cte dis - cus - su - - rus,

stri - cte, stri - cte dis - cus - su - - rus,

stri - cte, stri - cte dis - cta

stri - cte, stri - cte di -

8 cun - cta stri - cte, stri -

cun - cta stri - cte, stri dis - su -

rus!

rus!

8 rus!

PROBEPARTITUR

Ausgabequalität gegenüber Original evtl. gemindert • Evaluation Copy - Quality may be reduced • Carus-Verlag

# Tuba mirum

Andante

Basso solo

5

Tu - ba mi - rum spar - gens so -

- num, tu - - ba mi - rum spar - gens so - num per se -

12 pul - chra re - gi - o - num, co - get o - mnes an - te thr  
as an - te

17 Tenore solo  
8 Mors ra, cum re - sur - get cre - a -  
thro - n.

21 can - ti re - spon - su - ra, o - fe -

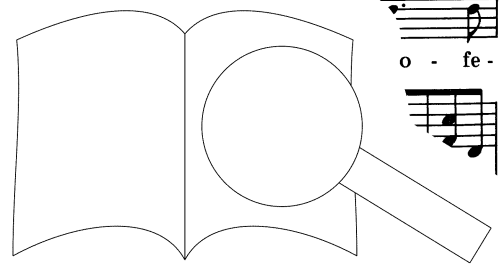

PROBENPARTITUR  
Ausgabequalität gegenüber Original evtl. gemindert • Evaluation Copy - Quality may be reduced • Carus-Verlag

26

re - tur, in quo to - tum con - ti - ne - tur, un - de mun - dus,

31 Alto solo

Ju - dex er - go cum se -  
mun - dus ju - di - ce - tur.

36

de - bit, quid - quid la - tet ap - tum re - ma -

40 Soprano solo

Quid sum mi - se, Quem pa - tro - num ro - ga -  
ne - bit.

44

Cum vix ju - stus,

49

Soprano

*sotto voce*

Alto *sotto voce*

Tenore *sotto voce*

Basso *sotto voce*

8

sit se - cu - rus, cum vix ju - stus, ju - stus

cum vix ju - stus, ju - stus

cum vix ju - stus, ju - stus

cum vix ju - stus, ju - stus

*sotto voce*

8

sit se - cu - rus, cum vix ju - stus, ju - stus

54

8

sit se - cu - rus, sit se - cu - rus, vix

sit se - cu - rus, cum vix

sit se - cu - rus, cum vix

*fp*

*p*

58

*resc.*

ju - stus, vix se - cu - rus.

ju - stus, se - cu - rus.

ju - stus sit se - cu - rus.

*cresc.*

ju - stus sit se - cu - rus.

*cresc.*

*f*

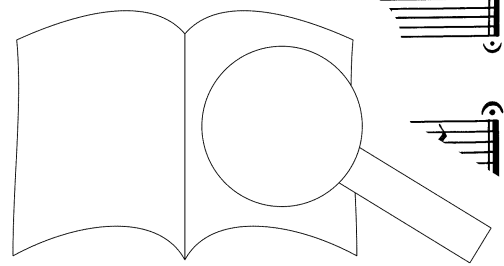

PROBENPARTITUR

Evaluation Copy - Quality may be reduced. Carus-Verlag

Ausgabequalität gegenüber Original evtl. gemindert.

# Rex tremendae

Adagio

Tutti *f*

Adagio

Rex,

\*

sta - tis, Rex tre - men - dae ma - je -  
 tis, Rex tre - men - dae ma - je - sta -  
 gra - tis, qui sal - van - dos sal - vas gra -  
 sal - vas gra - tis, sal - vas gra -

sta - tis, Rex tre - men - dae ma - je - sta - tis,  
 tis, Rex tre - men - dae ma - je - sta - tis,  
 tis, Rex tre - men - dae ma - je - sta -  
 tis, Rex tre - men - dae ma - je - sta - tis, Rex tre -

van - dos sa - vas gra - tis, Rex tre - men -  
 qui sal - vas gra - tis,  
 tis, Rex tre - men -  
 dae ma - je - sta - tis, Rex tre -

PROBEPARTITUR  
 Ausgabequalität gegenüber Original evtl. gemindert • Evaluation Copy - Quality may be reduced • Carus-Verlag

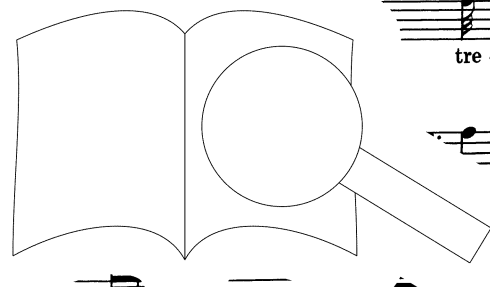



- - dae, Rex tre-men - dae ma - je - sta - tis, qui sal-van - dos sal - vas  
 Rex tre - men - dae ma - je - sta - tis, qui sal-van - dos sal - vas  
 8 - - dae, Rex tre-men - dae ma - je - sta - tis, qui sal-van - dos sal - vas  
 men - dae, Rex tre - men - dae ma - je - sta - tis, qui sal-van - dos sal - vas

gra - tis, sal - va me,  
 gra - tis, sal - va me,  
 8 gra - tis,  
 gra - tis,

ons pi - e - ta - tis,  
 va me, fons pi - e - ta - tis,  
 8 sal - va me, fons pi - e - ta  
 sal - va me, fons pi - e - t

PROBEPARTITUR  
 Ausgabqualität gegenüber Original evtl. gemindert • Evaluation Copy - Quality may be reduced • Carus-Verlag

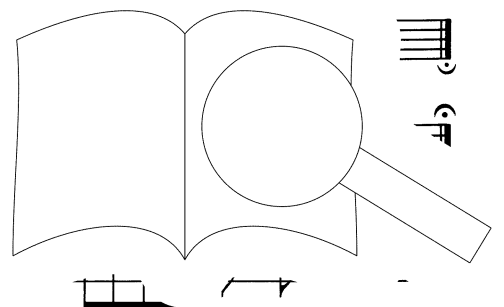

# Recordare

Andante

Measures 1-5 of the piano accompaniment. The treble clef part features a melodic line with a triplet of eighth notes in measure 3. The bass clef part provides a rhythmic accompaniment with trills in measures 3, 4, and 5.

Measures 6-10 of the piano accompaniment. The treble clef part continues the melodic line with trills in measures 7, 8, and 9. The bass clef part continues the rhythmic accompaniment.

11 Soprano solo

Vocal staves for Soprano, Alto, Tenore, and Basso solo. The Soprano staff has a rest. The Alto staff has a note on 'Re'. The Tenore and Basso staves have rests. The word 'cor' is written below the Tenore staff.

8 Basso solo

Basso solo staff with a note on 'Re'.

Measures 11-15 of the piano accompaniment. The treble clef part features a melodic line with trills in measures 11, 12, and 13. The bass clef part continues the rhythmic accompaniment.

16

Vocal staves with lyrics: 'da Je - su pi - e, Quod'. The Soprano staff has a note on 'da'. The Alto staff has a note on 'Je'. The Tenore staff has a note on 'su'. The Basso staff has a note on 'pi'. The Soprano staff has a note on 'e, Quod'.

Vocal staves with lyrics: 'da - re Je'. The Soprano staff has a note on 'da'. The Alto staff has a note on 're'. The Tenore staff has a note on 'Je'.

Measures 16-20 of the piano accompaniment. The treble clef part features a melodic line with trills in measures 16, 17, and 18. The bass clef part continues the rhythmic accompaniment.

sum cau - - - sa tu - ae vi - -

8 Quod sum cau - sa tu - - ae vi - -

21

ae: ne me per - das il - la di - e

ne me per

8 ae: ne me per - das il - la me

26 ne me per - das il - la di per - das,

per - das il - li e

per - das il

8 per - da: - e,

3- di - - e,

PROBEPARTITUR  
 Ausgabqualität gegenüber Original evtl. gemindert • Evaluation Copy - Quality may be reduced • Carus-Verlag

Se - di - sti las - sus:  
 Se - di - sti las - sus:  
 Quae - rens me,  
 Quae - rens me,

42  
 cru - cem pas - sus:  
 cru - cem pas - sus ta -  
 red - e - mi - sti tan - tus  
 red - e - mi - tan - tus

47  
 la - bor cas - sus, tan - tus la - bor non sit cas -  
 la - bor cas - sus, tan - tus la - bor non sit cas -  
 n sit cas - sus, tan - tus la - bor non sit cas -  
 non sit cas - sus,

PROBEPARTITUR  
 Ausgabequalität gegenüber Original evtl. gemindert • Evaluation Copy - Quality may be reduced • Carus-Verlag

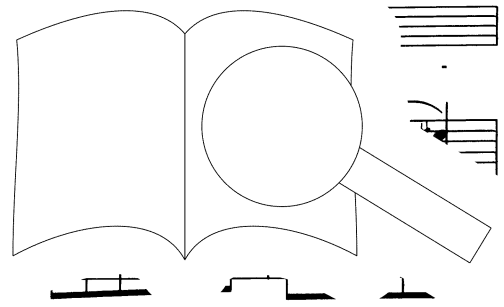

sus. Ju - ste ju - dex ul - ti -

sus.

8 sus. Ju - ste ju - dex ul - ti -

52 sus.

o - nis, do - num fac re - mis - si - o - nis, an -

8 o - nis, do - num fac re - mis - si - o - nis, - em

57 ra - ti -

ra - ti - o di - em ra - ti - o - nis.

an - te te di - em ra - ti - o - nis.

8 ra - an - te di - em ra -

- te di - em, di - em

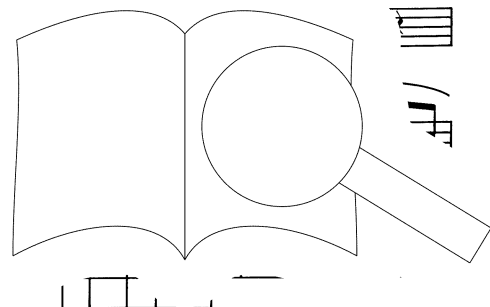

In - ge - mi - sco,  
 In - ge - mi - sco,  
 In - ge - mi - sco,  
 In - ge - mi - sco,

Piano accompaniment for measures 69-73, featuring a complex rhythmic pattern with eighth and sixteenth notes in both hands.

tam - quam re - us: cul - pa ru -  
 tam - quam re - us: cul - pa ru -  
 tam - quam re - us: cul - pa - tus  
 tam - quam re - us: cul - pa - tus

Piano accompaniment for measures 74-78, continuing the rhythmic pattern with chords and moving lines.

me - us: - ti par - ce De - us. Qui Ma -  
 me - us: - can - ti par - ce De - us.  
 sup - pli - can - ti  
 sup - pli - can - ti

Piano accompaniment for measures 79-83, including a section marked 'p' (piano) and a large graphic of an open book.

PROBE PARTITUR  
 Ausgabqualität gegenüber Original evtl. gemindert • Evaluation Copy - Quality may be reduced • Carus-Verlag

ri - am ab - sol - vi - sti, mi - hi quo - que spem de -  
 mi - hi quo - que spem de -  
 et la - tro - nem ex - au - di - sti, mi - hi

di - sti, mi - hi quo - que spem de - di - sti.  
 di - sti, mi - hi quo - que spem de - di - sti  
 quo - que, mi - hi quo - que spem de -  
 mi - hi quo - que spem sti.

ae non sunt di -  
 ces me - ae

PROBENPARTITUR  
 Ausgabqualität gegenüber Original evtl. gemindert • Evaluation Copy - Quality may be reduced • Carus-Verlag

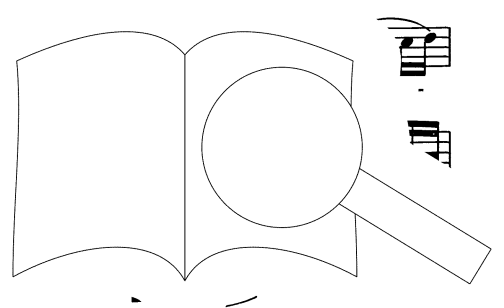

Sed tu bo - - - nus fac be -  
 gnae:  
 Sed tu bo - - - nus fac be -

ni - - gne, ne per - en - ni  
 ne per - en - ni  
 ni - - gne, ne per - en i - gne.  
 ne re - mer i - gne.

ves lo - cum prae - sta, et ab  
 ves lo - cum prae - sta, et ab  
 ter o - ves lo - ab  
 - ves lo - cum prae ab

PROBEPARTITUR  
 Ausgabequalität gegenüber Original evtl. gemindert • Evaluation Copy - Quality may be reduced • Carus-Verlag



hae - dis me se - que - stra, sta - tu - ens in par -

hae - dis me se - que - stra, sta - tu - ens in par -

hae - dis me se - que - stra, sta - tu - ens in par -

116 hae - dis me se - que - stra, sta - tu - ens in par -

- te de - xtra, sta - tu - ens in par -

- te de - xtra, sta - tu - ens in par -

- te de - xtra, sta - tu - ens in

- te de - xtra, de

- te de -

121

xtra.

xtra.

xtra.

126

PROBEPARTITUR

Ausgabequalität gegenüber Original evtl. gemindert • Evaluation Copy - Quality may be reduced • Carus-Verlag

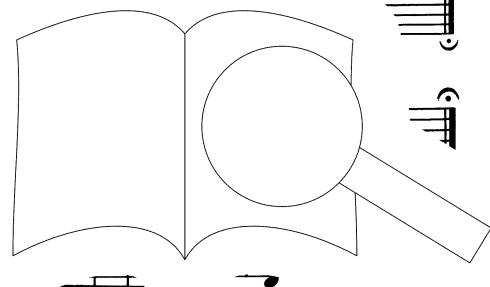

# Confutatis

Andante

*Tutti f*  
Con - fu - ta - tis ma - le -

*Tutti f*  
Con - fu - ta - tis ma - le - di - ctis,

di - ctis, cri - bus ad -

flam - mis a - cri - bus ad ctis, ma - le -

*Tutti sotto voce*  
*Tutti sotto voce*

di - ctis, a - cri - bus ad - di - ctis, Vo - ca, Vo - ca, p

PROBE PARTITUR  
Ausgabequalität gegenüber Original evtl. gemindert • Evaluation Copy - Quality may be reduced • Carus-Verlag

vo - ca me, vo - ca me cum be - ne - di - ctis.

vo - ca me, vo - ca me cum be - ne - di - ctis.

Con - fu-

Con - fu - ta - tis m.

- ta - tis ma - le - di 3, flam - mis

flam - bus ad - di - ctis, con - fu - ta - tis ma - le -

- ctis, con - fu - ta -

le -

\* ♩ Schreibweise im Original (siehe Partitur)

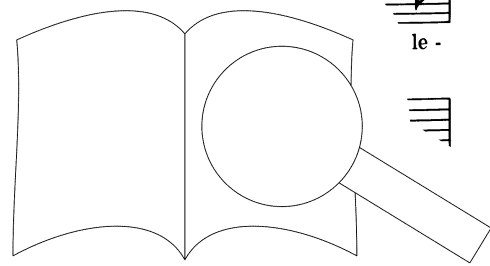

sotto voce

Vo - ca,  
sotto voce  
Vo - ca,

di - ctis, flam - mis a - cri - bus ad - di - ctis,

di - ctis, flam - mis a - cri - bus ad - di - ctis,

*p*

vo - ca me cum be - ne - di - ctis, cum be - ne - dic - ctis, v

vo - ca me, vo - ca me cum be - ne - di -



vo - ca me,

cum be - ne - di - ctis.

me,

um be - ne - di - ctis.



Ausgabequalität gegenüber Original evtl. gemindert • Evaluation Copy - Quality may be reduced • Carus-Verlag

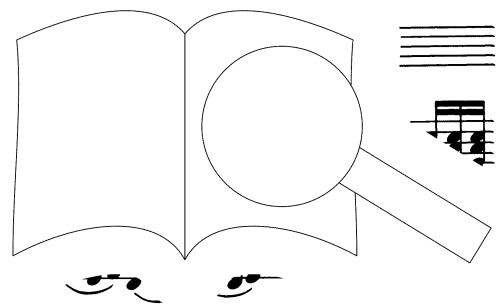

(25)

*p*  
O - ro sup - plex et ac -

*p*  
O - ro sup - plex et ac -

*p*  
O - ro sup - plex et ac -

*p*  
O - ro sup - plex et ac -

(25)

28

cli - - - nis,

cli - - - nis,

cli - - - nis,

cli - - - nis,

28

(30)

cor con - - - si ci - - -

cor con qua - si ci - - -

cor am qua - si

- tum qua - si

PROBEPARTITUR  
Ausgabequalität gegenüber Original evtl. gemindert • Evaluation Copy - Quality may be reduced • Carus-Verlag

33

nis: ge - re cu - .

nis: ge - re cu - .

8 nis: ge - re cu - .

nis: ge - re cu - .

(35)

ram, ge - re cu - ram

ram, ge - re cu

8 ram, ge - re - i

- ram, cu - - i

38

fi

fi nis,

8 fi nis.

- nis.

38

Carus 40.630/03

PROBEPARTITUR

Ausgabequalität gegenüber Original evtl. gemindert • Evaluation Copy - Quality may be reduced • Carus-Verlag

# Lacrymosa

Andante [ $\leftarrow$   $\bullet$  =  $\bullet$ .  $\rightarrow$ ]

3 *p*

La - cry - mo - sa di - es il - la,  
La - cry - mo - sa di - es il - la,  
La - cry - mo - sa di - es il - la,  
La - cry - mo - sa di - es il - la,

Andante

*p*

5

qua re - sur - get ex fa - vil - la ju - di - can - dus  
qua re - sur - get ex fa - vil - la ju - di - car ho - us:  
qua re - sur - get ex fa - vil - la ju - di re - us:  
qua re - sur - get ex fa - vil - la ju - di - ca - to - mo re - us:

*cresc.*

*cresc.*

5

*cresc.*

9

hu - ic er - go par - ce De -  
hu - ic er - go par - ce De -  
hu - ic er - go par - ce De -  
hu - ic

*p*

9

*p*

us. Pi - e Je - su, pi - e Je - su Do - mi-ne,

us. Pi - e Je - su, pi - e Je - su Do - mi-ne,

us. Pi - e Je - su, pi - e Je - su Do - mi-ne,

us. Pi - e Je - su, pi - e Je - su Do - mi-ne,

do - na e - is, do - na e - is re - qui -

do - na e - is, do - na e - is re - qui -

do - na e - is, do - na e - is re -

do - na e - is, do - na e - is qui - em,

do - na e - is re - qui - em.

do - na e - is re - qui - em.

e - is

e - is

PROBE PARTITUR

Ausgabequalität gegenüber Original evtl. gemindert • Evaluation Copy - Quality may be reduced • Carus-Verlag

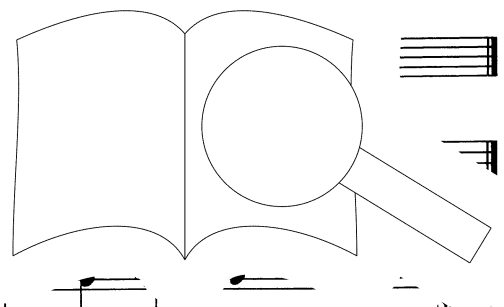



Amen

Allegro [ $\leftarrow \text{♩} = \text{♩} \rightarrow$ ]

2 *f*  
A - - men, a - - men, a - -

*f*  
A - - - - - men,

*f*  
A - - -

Allegro

2

8  
men, a - men, a - men, a - men, a - men, a  
a - - men, a - - men, a

8

15  
men,  
a - mer - - - - - a - - - - -  
- - men, a - - men, a - - - - - men,  
men, a - -

15

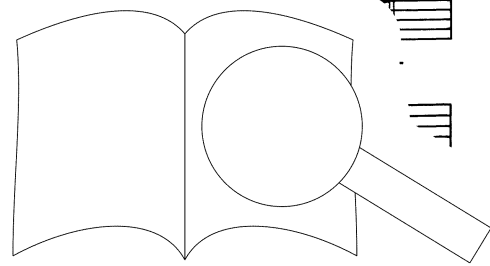

PROBEPARTITUR  
Ausgabequalität gegenüber Original evtl. gemindert • Evaluation Copy - Quality may be reduced • Carus-Verlag

men, a

a - men, a - men, a - men, a - men, a

a - - - men, a - - - men, a - - - men,

- - - men, a - men, a

men, a - men, a - - - men, a - - - men, a

men, a - men, a

a - - - men,

a

mer a

a - men,

men, a

a

- - - men,

- - - men, a - men,

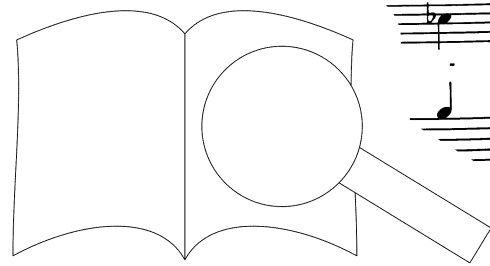
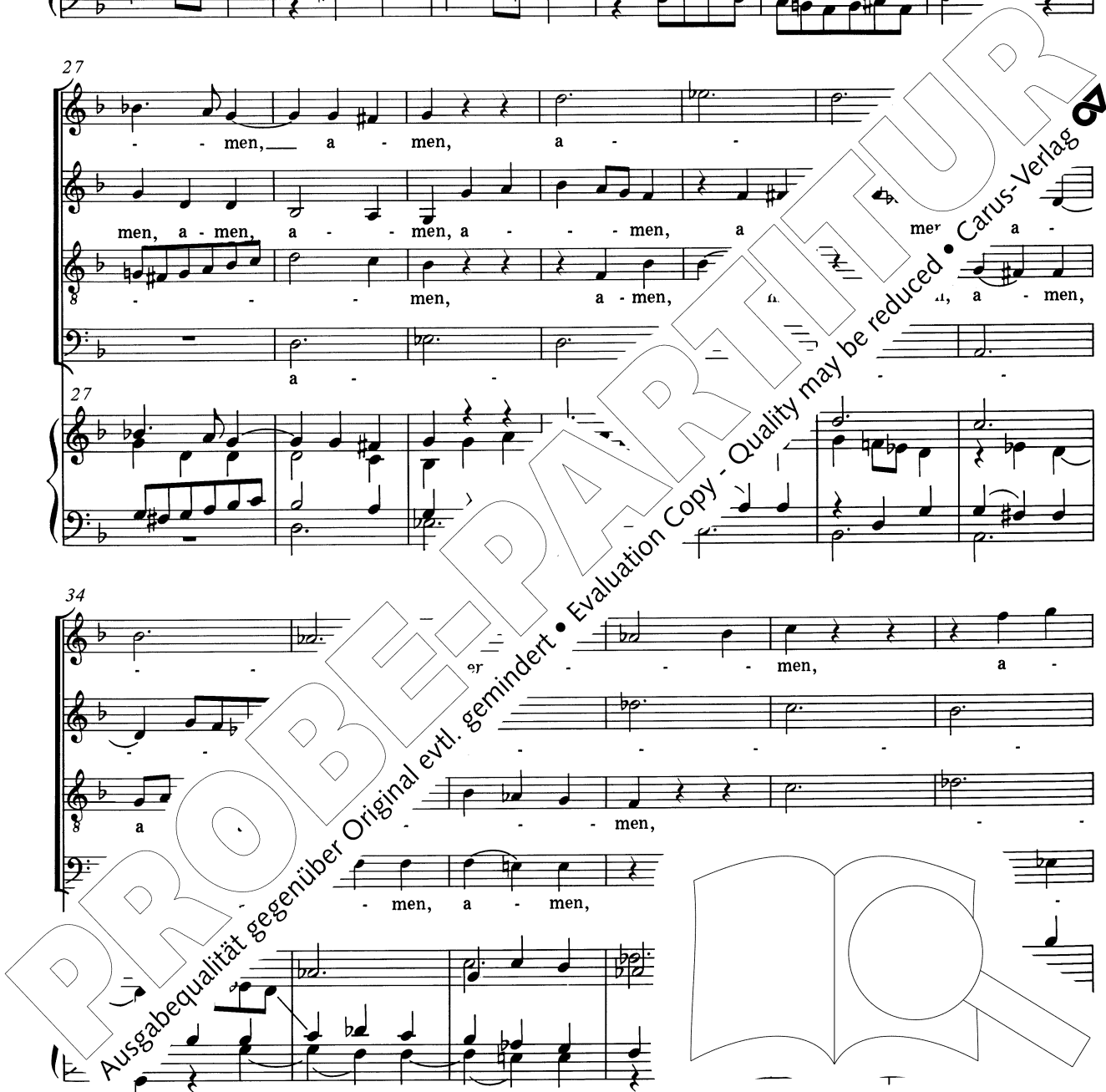

40

men, a - - - men, a - - -

- - - - - men, a - - - men, a - - -

8 - - - - - men, a - - -

men, a - - - men, a - - -

46

men, a - - - men, a - - - men, a - - - men, a - - -

- - - - - men, a - - - men, a - - - men, a - - -

8 - - - - - - men, a - - - men, a - - - a - - - men,

men, a - - - a - - -

53

a - - - men, a - - -

mer - - - men,

a - - - men, a - - -

PROBEPARTITUR

Ausgabequalität gegenüber Original evtl. gemindert • Evaluation Copy - Quality may be reduced • Carus-Verlag

men, a - - - - -

a - - - - - men, a -

men, a - - - - - men, a - men, a - men, a -

men, a - men, a - - - - - men, a -

- - - - - men, a - men, a -

- - - - - men, a - - - - - men, a - men, a -

men, a - men, a - men, a - - - - - men, a -

men. \_\_\_\_\_

men. \_\_\_\_\_

a - - - - -

.en, a - - - - -

PROBEPARTITUR

Ausgabequalität gegenüber Original evtl. gemindert • Evaluation Copy - Quality may be reduced • Carus-Verlag

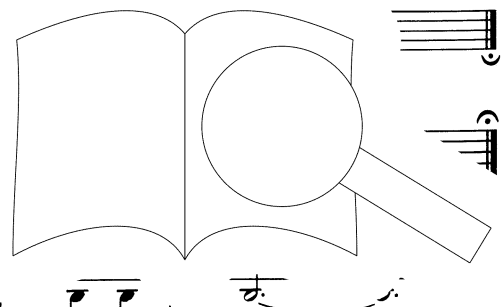

# Offertorium

## Domine Jesu

Allegro

Tutti *p*

Do - mi - ne Je - su Chri - ste, Rex glo - ri - ae, Rex glo - ri - ae,  
Do - mi - ne Je - su Chri - ste, Rex glo - ri - ae, Rex glo - ri - ae,  
Do - mi - ne Je - su Chri - ste, Rex glo - ri - ae, Rex glo - ri - ae,  
Do - mi - ne Je - su Chri - ste, Rex glo - ri - ae, Rex glo - ri - ae,

Allegro

li - be - ra a - ni - mas o - mni - um fi - de -  
li - be - ra a - ni - mas o - mni - um fi - de -  
li - be - ra a - ni - mas o - mni - um fi - de -  
li - be - ra a - ni - mas o - mni - um fi - de -

rum de poe - ni, de poe - nis in - fer -  
rum de poe - ni, de poe - nis in - fer -  
rum de poe - nis in - fer - ni,  
de poe - nis in - fer - ni,

PROBEKOPPIE  
Ausgabequalität gegenüber Original evtl. gemindert • Evaluation Copy - Quality may be reduced • Carus-Verlag

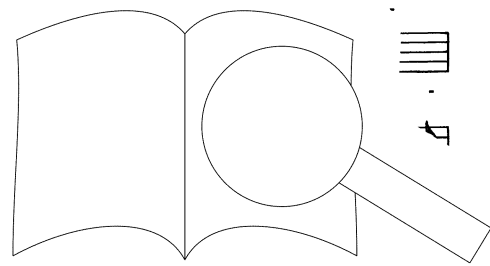

ni, et de pro - fun - - do la - - - cu:

ni, et de pro - fun - - do la - - - cu:

ni, et de pro - fun - - do la - - - cu:

ni, et de pro - fun - - do la - - - cu:

li - be - ra, li - be - ra e - - as de o

li - be - ra e - - as de nis,

li - be - ra e - - as - o - nis,

li - be - ra e - - as re le - o - nis,

li - be - ra, - as de o - re le - o - nis,

- as de o - re le - o - nis,

- ra e - - as - nis,

- be - ra e - - as nis,

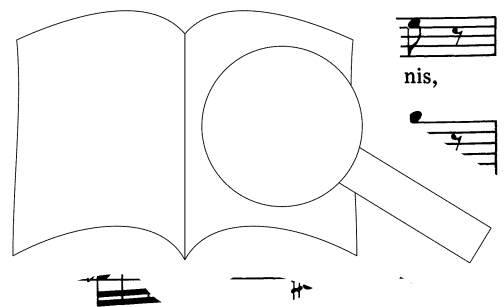

PROBEPARTITUR  
 Ausgabequalität gegenüber Original evtl. gemindert • Evaluation Copy - Quality may be reduced • Carus-Verlag

ne ab-sor-be-at e-as  
 ne ab-sor-be-at e-as tar-ta-rus, ne ca-dant in ob-scu-rum, ne ca-dant,

21

24  
 ne ab-sor-be-at e-as tar-ta-ru  
 tar-ta-rus, ne ca-dant in ob-scu-rum, ne ca-dant, in  
 ne ca-dant in ob-scu-rum, ne ca-dant, -dant in ob-

24

27  
 scu-rum, r at in ob-scu-rum, ne ca-dant,  
 rum, ne ca-dant ant, ne ca-dant in ob-scu-rum, ne ca-dant,  
 scu-rum ca-dant, ne ca-dant in ca-dant,  
 at e-as tar-ta-rus, ne ca-dant in ne

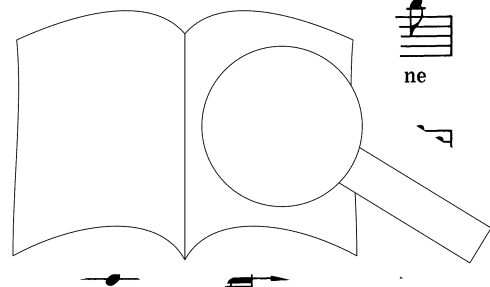

PROBEPARTITUR  
 Ausgabequalität gegenüber Original evtl. gemindert • Evaluation Copy - Quality may be reduced • Carus-Verlag

30

ne ca-dant in ob - scu - rum: sed si - gni-fer san - ctus

ne ca-dant in ob - scu - rum:

ne ca-dant in ob - scu - rum:

ca-dant in ob - scu - rum:

*p* *p* *p* *p*

Solo

30

*p*

34

Mi - cha-el re - prae-sen-tet e - as

Solo

sed si - gni-fer san - ctus Mi - cha-

gni-fer san - ctus

34

38

san - ctam, re - prae - sen-tet, re - prae-sen-tet e - as

lu - cem sanc - tam, re - prae - sen - tet, re-prae-sen-tet

Mi - prae-sen-tet e - as

si - gni-fer san - ctus Mi - prae-

38

PROBEPARTITUR

Ausgabequalität gegenüber Original evtl. gemindert • Evaluation Copy - Quality may be reduced • Carus-Verlag

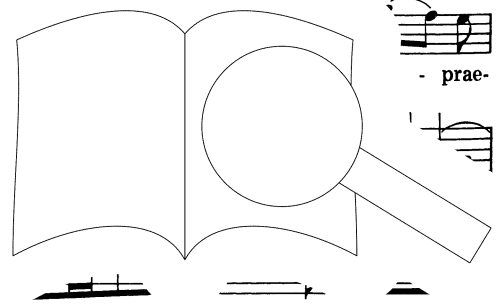



in lu - cem san - ctam:  
 e - - as in lu - cem san - ctam:  
 in lu - cem san - ctam:  
 sen-tet e - as in lu - cem san - ctam: *Tutti f* Quam o - lim A - bra-hae

42 *f*

45 *Tutti f*  
 Quam o - lim A - bra-hae pro - m:  
 pro - mi - si - sti, et se - mi-ni e A - bra-hae

45

48 *Tutti f*  
 Quam o - lim A - h  
 Quam o - lim A - bra-hae pro mi -  
 ro - mi - si - sti, et se - mi-ni e - jus,  
 ni e - jus, pro - m: mi -  
 sti, pro - mi - si - sti,

48

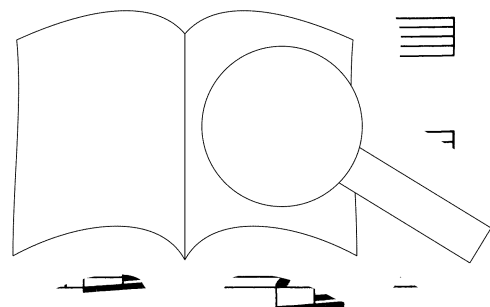

si - sti, quam o - lim A - bra-hae pro - mi -  
 quam o - lim A - bra-hae pro - mi - si - sti,  
 si - sti,

51

si - sti, pro  
 et se - mi-ni e - jus, quam o - lim  
 quam o - lim A - bra-hae pro - mi - si -  
 quam o - lim

53

et se -  
 A re  
 et se - mi-ni e - jus, quam o - lim  
 pro - mi - si - sti, quam o - lim  
 mi - si - sti, quam o -  
 quam o - lim  
 et se - mi-ni e -  
 hae

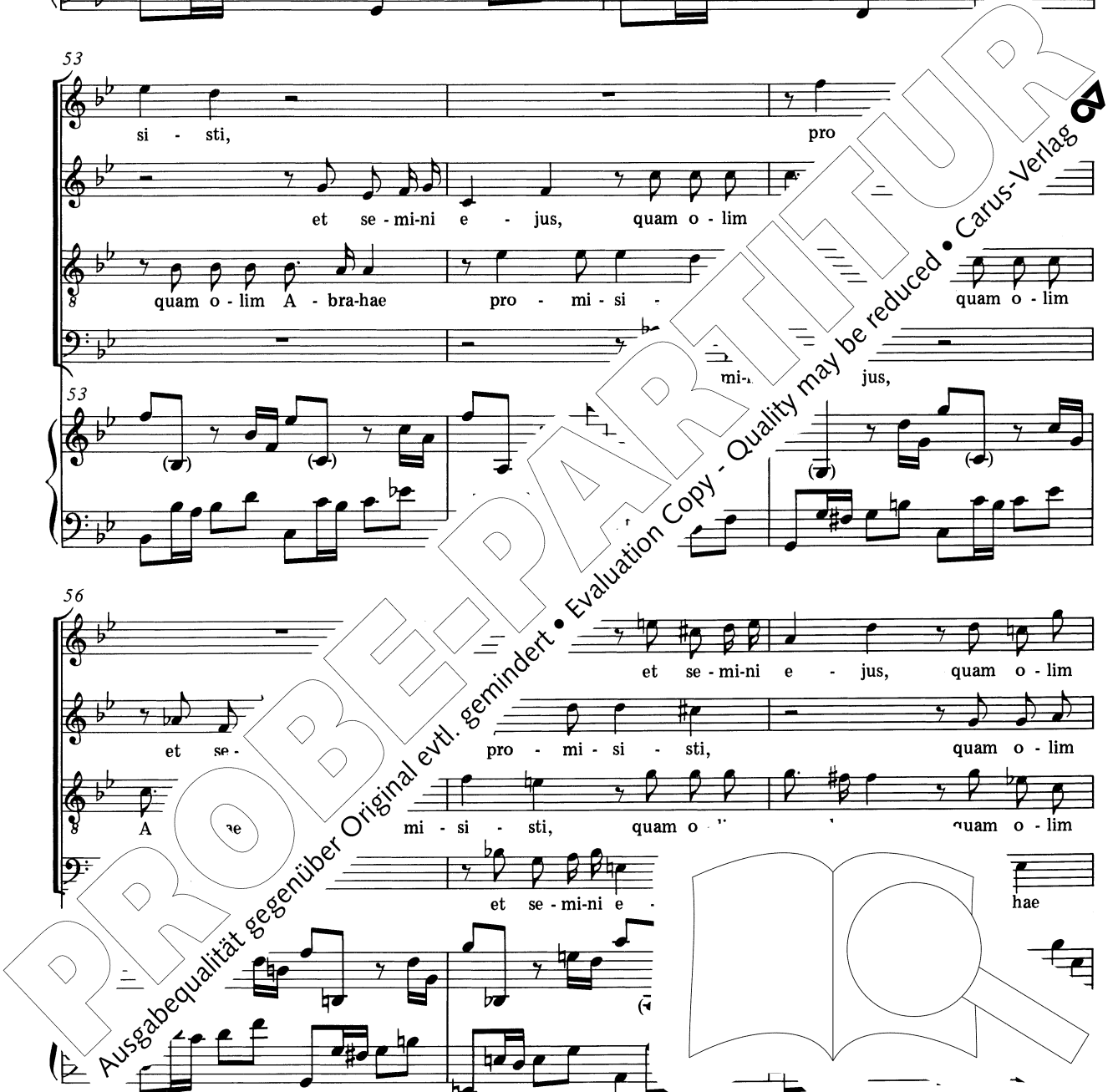

A - bra-hae pro - mi - si - sti, pro - mi - si - sti, quam o - lim A - bra-hae  
 A - bra-hae pro - mi - si - sti, pro - mi - si - sti, quam o - lim  
 8 A - bra-hae pro - mi - si - sti, pro - mi - si - sti, quam o - lim  
 pro - mi - si - sti, pro - mi - si - sti, quam o - lim

pro - mi - si - sti, quam o - lim A - bra-hae pro -  
 A - bra-hae pro - mi - si - sti, quam o - lim mi -  
 8 A - bra-hae pro - mi - si - sti, quam o pro - mi -  
 A - bra-hae pro - mi - si - sti, pro - mi -

et se jus, et se - mi - ni e -  
 si - sti, e - jus, et se -  
 8 si - mi - ni e - jus,  
 se - mi - ni e - jus,

*p* *p* *p* *p*

PROBEPARTITUR  
 Ausgabegüte gegenüber Original evtl. gemindert • Evaluation Copy - Quality may be reduced • Carus-Verlag

69

jus, et se - mi - ni e - jus, quam o - lim  
 se - mi - ni, se - mi - ni e - jus, quam o - lim  
 mi - ni, se - mi - ni e - jus, quam o - lim  
 mi - ni, se - mi - ni e - jus, quam o - lim A - bra-ae

72

A - bra-ae pro - mi - si - sti, quam o - lim A - b  
 A - bra-ae pro - mi - si - sti, quam o - lir ro-mi  
 A - bra-ae pro - mi - si - sti, quam ai - si  
 pro - mi - si - sti, quam o - lim ro-mi pro-mi - si

75

sti, et se ni e - jus.  
 sti, mi - ni, se - mi - ni e - jus.  
 se - mi - ni, se - mi - ni  
 et se - mi - ni, se - mi - ni

PROBE PARTUR  
 Ausgabegüte gegenüber Original evtl. gemindert • Evaluation Copy - Quality may be reduced • Carus-Verlag

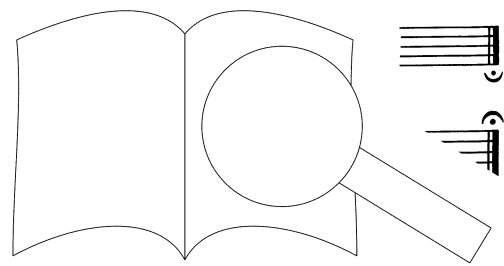

# Hostias

Andante

Tutti *f*

Ho - sti - as et pre - ces ti - bi Do - mi - ne,  
Ho - sti - as et pre - ces ti - bi Do - mi - ne,  
Ho - sti - as et pre - ces ti - bi Do - mi - ne,  
Ho - sti - as et pre - ces ti - bi Do - mi - ne,

Andante

7  
ti - bi Do - mi - ne lau - dis of - fe - ri - mus:  
ti - bi Do - mi - ne lau - dis of - fe - ri - mus sci - pe  
ti - bi Do - mi - ne lau - dis of - fe - ri - mus su - sci - pe  
ti - bi Do - mi - ne lau - dis of - fe - ri - mus tu su - sci - pe

13  
*p* pro a - ni - lis, qua - rum ho - di - e me - mo - ri - am  
*p* pro a - ni - lis, qua - rum ho - di - e, ho - di - e me -  
*p* pro - bus il - lis, qua - rum ho - di - e me -  
bus il - lis, qu - me -

fa - ci - mus, ho - sti - as et  
 mo - ri - am fa - ci - mus, ho - sti - as et  
 mo - ri - am fa - ci - mus, ho - sti - as et  
 mo - ri - am fa - ci - mus, ho - sti - as et

pre - ces ti - bi Do  
 pre - ces ti - bi  
 pre - ces ti - bi  
 pre - ces ti - bi

lau - ri - mus: tu su - sci - pe pro a - ni -  
 lau - fe - ri - mus: tu su - sci - pe pro a - ni -  
 of - fe - ri - mus: a - ni -  
 .is of - fe - ri - mus: - ni -

PROBEPARTITUR  
 Ausgabequalität gegenüber Original evtl. gemindert • Evaluation Copy - Quality may be reduced • Carus-Verlag

ma - bus il - lis, qua - rum ho - di - e, ho - di - e me - mo - ri - am -  
 ma - bus il - lis, qua - rum ho - di - e me - mo - ri - am fa - -  
 ma - bus il - lis, qua - rum ho - di - e me - mo - ri - am fa - -  
 ma - bus il - lis, qua - rum ho - di - e, ho - di - e me - mo - -

fa - ci - mus: fac e -  
 - ci - mus: fac Do ne, de  
 - ci - mus: fac - mi - ne, de  
 ri - am fa - ci - mus: f e „ Do - mi - ne, de

mor - te tran - vi - tam.  
 mor - te tran - ad vi - tam.  
 mor - i - re ad vi -  
 trans - i - re ad vi -

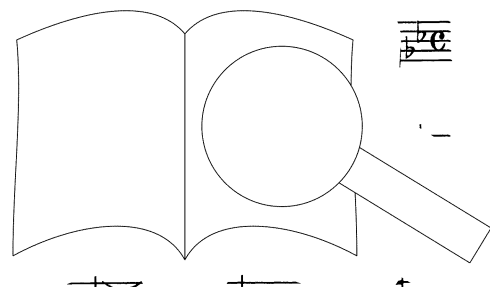

PROBE PARTITUR  
 Ausgabequalität gegenüber Original evtl. gemindert • Evaluation Copy - Quality may be reduced • Carus-Verlag

Quam o - lim A - bra-hae pro - mi - si - sti, et se - mi-ni e - jus,

Quam o - lim A - bra-hae si - sti, quam o - lim A - bra-hae et pro - mi - ti, mi - si - sti,

A - bra-hae et si - sti, quam o - lim A - bra-hae pro - mi - si - sti,

PROBEPARTITUR  
Ausgabequalität gegenüber Original evtl. gemindert • Evaluation Copy - Quality may be reduced • Carus-Verlag

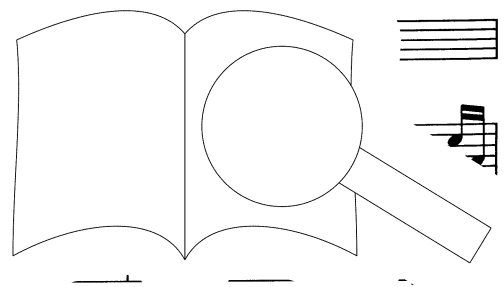



si - sti, pro - mi - si - sti,  
 et se - mi - ni e - jus, quam o - lim A - bra - hae,  
 8 quam o - lim A - bra - hae pro - mi - si - sti, quam o - lim  
 et se - mi - ni e - jus,

64

et se - mi - ni e -  
 et se - mi - ni e - jus pro - mi - si - sti, - lim  
 8 A - bra - hae pro - mi - si - sti, quam o - lim  
 et se - mi - ni e - lim A - bra - hae

67

A - bra - hae ni - si - sti, quam o - lim A - bra - hae  
 A - bra - hae sti, pro - mi - si - sti, quam o - lim  
 8 A - ni - si - sti, pro - mi - si - sti, - lim  
 sti, pro - mi - si -

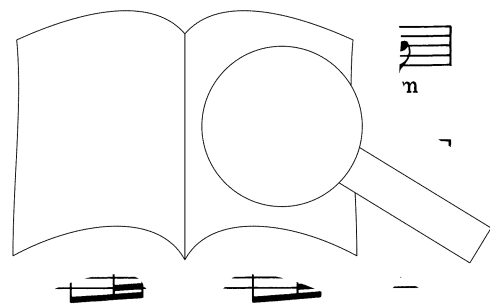

PROBENPARTITUR  
 Ausgabequalität gegenüber Original evtl. gemindert • Evaluation Copy - Quality may be reduced • Carus-Verlag

pro - mi - si - sti, quam o - lim A - bra-hae pro - mi - si - sti,  
 A - bra-hae pro - mi - si - sti, quam o - lim A - bra-hae pro - mi -  
 A - bra-hae pro - mi - si - sti, quam o - lim A - bra-hae pro - mi -  
 A - bra-hae pro - mi - si - sti quam o - lim A - bra-hae pro - mi -

et se - mi - ni e - jus,  
 si - sti, et se - mi - ni e - jus,  
 si - sti, et se - mi - ni e - jus,  
 si - sti, et se - mi - ni e - jus,

- mi - ni - jus, et se - mi - ni e -  
 se - mi - ni, se - mi - ni e -

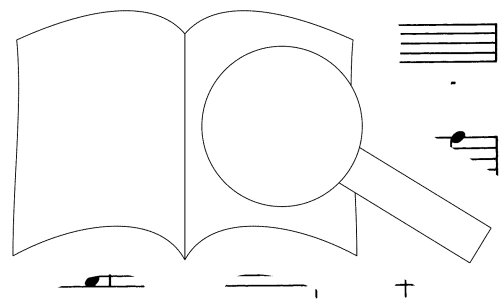

PROBEPARTITUR  
 Evaluation Copy - Quality may be reduced • Carus-Verlag

82

jus, quam o - lim A - bra-hae pro - mi -  
 jus, quam o - lim A - bra-hae pro - mi -  
 jus, quam o - lim A - bra-hae pro - mi -  
 jus, quam o - lim A - bra-hae pro - mi - si - sti,

82

84

si - sti, quam o - lim A - bra-hae pro - mi - si  
 si - sti, quam o - lim A - bra-hae pro -  
 si - sti, quam o - lim A - bra-hae pro - mi - si  
 quam o - lim A - bra-hae pro - mi - si

84

86

sti, et se - ni e - - jus.  
 sti, ni, se - mi - ni e - - jus.  
 sti - mi - ni, se - mi - ni  
 se - mi - ni, se - mi - ni

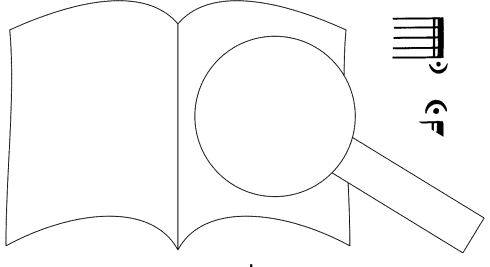

# Agnus Dei

**Larghetto** **Tutti *f***

**Tutti *f*** A - gnus De - - -

**Larghetto** A - gnus De - - -

4

i, qui tol - - -

i, qui tol - - - pec -

i, qui tol - - - pec -

i, qui tol - - - pec -

7

ca - - - di:

ca - - - di:

ca - - - di:

mun - - - di:

mun - - - na,

11

*p*  
do - na e - - is re - - qui - em.  
*p*  
do - na e - - is re - - qui - em.  
*p*  
do - na e - - is re - - qui - em.  
do - - na e - - - is re - - - qui - em.

11

11  
*f*  
*f*  
A - gnus De - - i,  
A - gnus De - - i,  
A - gnus De - - i,  
A - gnus De - - i,  
A - gnus De - - i,  
A - gnus De - - i,  
A - gnus De - - i,  
A - gnus De - - i,

15

15  
*f*  
*f*  
A - gnus De - - i,  
A - gnus De - - i,  
A - gnus De - - i,  
A - gnus De - - i,  
A - gnus De - - i,  
A - gnus De - - i,  
A - gnus De - - i,  
A - gnus De - - i,

15

15  
A - gnus De - - i,  
A - gnus De - - i,  
A - gnus De - - i,  
A - gnus De - - i,  
A - gnus De - - i,  
A - gnus De - - i,  
A - gnus De - - i,  
A - gnus De - - i,

18

18  
tol - pec - ca - - ta  
tol - pec - ca - - ta  
tol - pec - ca - - ta  
lis pec  
lis pec  
lis pec  
lis pec

18

18  
tol - pec - ca - - ta  
tol - pec - ca - - ta  
tol - pec - ca - - ta  
lis pec  
lis pec  
lis pec  
lis pec

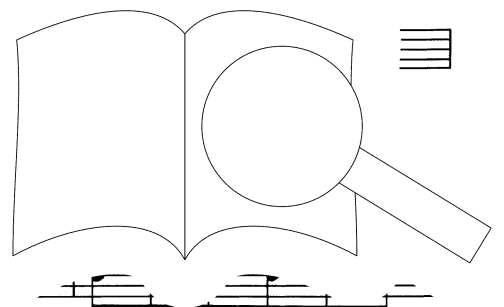

PROBEPARTITUR  
Ausgabequalität gegenüber Original evtl. gemindert • Evaluation Copy - Quality may be reduced • Carus-Verlag

21

mun - - - di: do - na, do - na e - is

mun - - - di: do - na e - is,

mun - - - di: do - na e - is,

mun - - - di: do - na,

21

*p*

26

re - - - qui

do - - na e - is re et.

do - - na e - is re

do - - na e - is em.

26

*f*

30

*f*

A

De - - - i, qui

De - - - i, qui

De - - - gnus De - - -

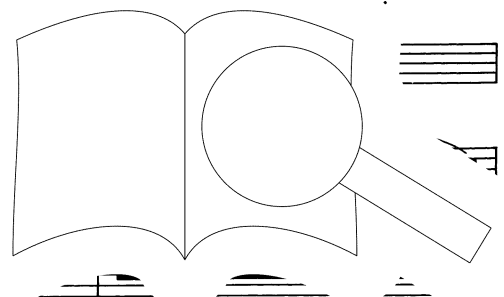

PROBEPARTITUR  
 Ausgabequalität gegenüber Original evtl. gemindert • Evaluation Copy - Quality may be reduced • Carus-Verlag

tol - - - lis pec - ca - lis - ta

tol - - - lis pec - ca - lis - ta

tol - - - lis pec - ca - lis - ta

tol - - - lis pec - ca - lis - ta

mun - - - di: do - na e - - is

mun - - - di: do - na e - - is

mun - - - di: do - na

mun - - - di: do - na, do - - - - - qui -

mun - - - di: do - na, do - - - - - re - qui -

em sem - - - - - nam.

em - - - - - ter - - - - - nam.

em - - - - - em - pi - ter - - - - - am.

em - - - - - sem - pi - ter - - - - -

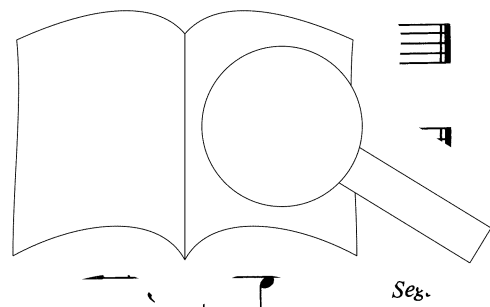

PROBEPARTITUR  
 Ausgabequalität gegenüber Original evtl. gemindert • Evaluation Copy - Quality may be reduced • Carus-Verlag

# Communio

## Lux aeterna

Adagio

Soprano solo

*p*  
Lux ae - ter - na lu -

4  
- ce - at e - is, Do - mi - ne. - c. ae -

7  
ter - num, qui - a pi  
Tutti *f*  
Lux ae -  
Tutti *f*  
Lux ae - ter - na, ae - ter - na,  
Tutti *f*  
Lux ae - ter - na, ae - ter - na, ae -  
Tutti *f*  
Lu: ae -

*f*

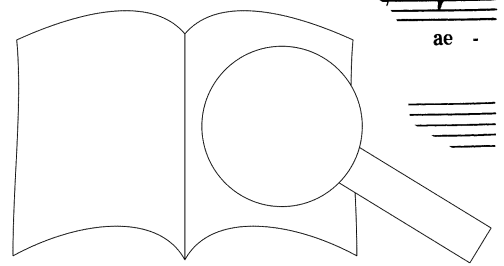

PROBEPARTITUR  
Ausgabequalität gegenüber Original evtl. gemindert • Evaluation Copy - Quality may be reduced • Carus-Verlag



(9)

ter - na lu - ce - at e - is, Do - mi - ne.

ae - ter - na lu - ce - at e - is, Do - mi - ne. Cum san - ctis,

8 ter - - na lu - ce - at e - is, Do - - mi - ne. Cum san - ctis, cum

ter - - na lu - ce - at e - is, Do - - mi - ne. Cum san - ctis, cum

(9)

12

Cum san - ctis tu - is in ae - ter - num, qui - a pi - - us es.

cum san - ctis tu - is in ae - ter - num, qui - a pi -

8 san - ctis tu - is in ae - ter - num, qui - a pi - es

12 san - ctis tu - is in ae - ter - num, qui - a

12

15

Do - na, do - na e - is

Re - qui - e

PROBENPARTITUR

Ausgabequalität gegenüber Original evtl. gemindert • Evaluation Copy - Quality may be reduced • Carus-Verlag

*f*  
 Do - na, do - na e - is Do - mi-ne, do - na,  
 Do - mi-ne, do - na, do - na e - is re - qui - em ae - ter -  
 - qui - em ae - ter - nam do - na, do - na  
 nam do - na, do - na e - is, e - is

18

do - na e - is re - qui - em ae - ter -  
 - nam, do - na e - is Do - mi-ne, do - na  
 e - is, do - na e - is, do - na  
 Do - mi-ne, do - na e - is, do - na

21

- nam, ae - x per - pe - tu - a, et lux per - pe - tu - a  
 e - na: et lux per - pe - tu - a, et lux per -  
 - na: et lux per -  
 so - na: et lux per -

24

PROBEPARTITUR  
 Original evtl. gemindert • Evaluation Copy - Quality may be reduced • Carus-Verlag

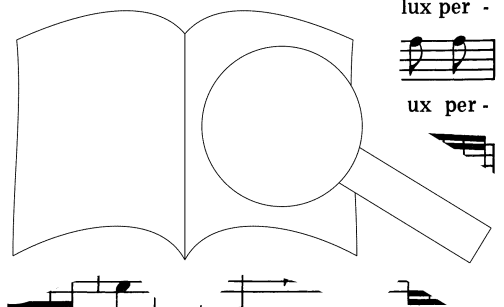

lu - ce - at e - is, et lux per - pe - tu - a lu - ce - at e - is.

pe - tu - a lu - ce - at e - is, et lux per - pe - tu - a lu - ce - at e - is.

pe - tu - a lu - ce - at e - is, et lux per - pe - tu - a lu - ce - at e - is.

pe - tu - a lu - ce - at e - is, et lux per - pe - tu - a lu - ce - at e - is.

## Cum sanctis

Allegro

In ae - ter

Cum san - ctis tu - - is

Cum tu - is in ae - ter -

num, ae - ter - num,

ctis -

7

num, ae - ter - - num, ae - ter - -  
cum san - ctis tu - - is in ae -  
tu - is in ae - ter - - num, ae - ter - num, in ae - ter -

10

- - num, in ae - ter - - - num,  
ter - - - num,  
cum tu - -  
num, ae -

13

ter - -  
ae - ter is - -  
am, ae - ter - num, ae - ter -  
num, ae - ter - num

PROBEPARTITUR  
Ausgabequalität gegenüber Original evtl. gemindert • Evaluation Copy - Quality may be reduced • Carus-Verlag

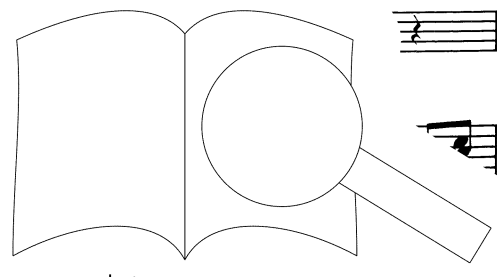

num, cum san - ctis tu - - is in ae - ter - -  
 - num, in ae - ter - num, ae - ter - num,  
 - num, ae - ter - - num,  
 ae - ter - - num, in ae - ter - -

16

- - - num, in  
 ae - ter - - - num,  
 cum san - ctis in ae -  
 - num,

19

- - - num,  
 - - - num, in ae -  
 ter  
 cum

22

PROBEPARTITUR  
 Ausgabequalität gegenüber Original evtl. gemindert • Evaluation Copy - Quality may be reduced • Carus-Verlag

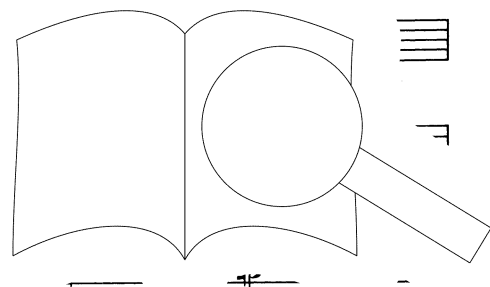

cum

ter

num, ae - ter

is in ae - ter

san - ctis tu - is in ae - ter

num, ae - ter - num, ae - ter

num, in ae - ter

num,

ctis tu -

num, ae - ter

ter - num,

cum san - ctis tu -

er

n ae -

PROBEPARTITUR

Ausgabequalität gegenüber Original evtl. gemindert • Evaluation Copy - Quality may be reduced • Carus-Verlag

34

ae - ter - - - num, in ae -  
 is in ae - ter -  
 8 in ae - ter - - - num, ae - ter - - -  
 ter - - - num, ae - ter - - - num,

34

37

ter - - - num, ae - ter - - - num,  
 num, ae - ter - - - num, cum san - ctis tu - -  
 num, ae - ter - num, in ae - ter - - -  
 in ae - ter - - - san - ctis

37

40

in ae - ter - - - num, ae -  
 num, in ae -  
 num, in ae - ter - - - num, ae -  
 in ae - ter - - - ae -

8

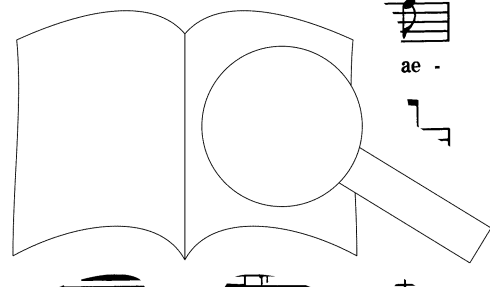

PROBEPARTITUR  
 Ausgabqualität gegenüber Original evtl. gemindert • Evaluation Copy - Quality may be reduced • Carus-Verlag

ter - - num, ae - ter - num, in ae -  
 ter - - num, cum san - ctis tu - - is in ae - ter - -  
 ter - - num, ae - ter - num, ae - ter - - num, in ae -  
 ter - - num, in ae - ter - -

43

ter - - num, in ae - ter - -  
 num, in ae - ter - - ctis  
 ter - - num, ae - ter - num, ae - an - ctis  
 num, ae - ter - num, ae - ter - num, ae - ter -

46

-num, ae - tr  
 tu - is in  
 tu -  
 num, qui - a pi - - us es.  
 qui - a pi - - us es.  
 num, qui - a pi  
 num, qui - a

Adagio

PROBEPARTITUR  
 Ausgabequalität gegenüber Original evtl. gemindert • Evaluation Copy - Quality may be reduced • Carus-Verlag

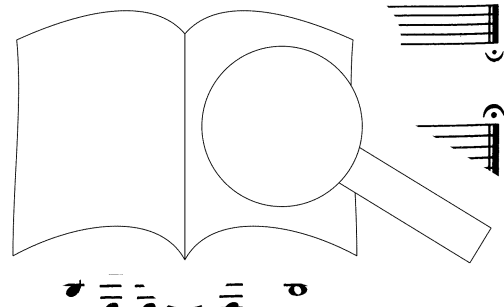



# Sanctus

Adagio

San - ctus, San - ctus, San - ctus Do - mi - nus De - us

San - ctus, San - ctus, San - ctus Do - mi - nus De - us

San - ctus, San - ctus, San - ctus Do - mi - nus De - us

San - ctus, San - ctus, San - ctus Do - mi - nus De - us

Adagio

Sa - ba-oth. Ple - ni sunt cae - li et ter

Sa - ba-oth. Ple - ni sunt cae - li et ter ra - ri - a,

Sa - ba-oth. Ple - ni sunt cae - li et glo - ri - a,

Sa - ba-oth. Ple - ni sunt cae - e. ra glo - ri - a,

glo - ri - a, glo a.

glo - ri - a.

glo - ri - a tu

ri - a tu

ex -

Allegro

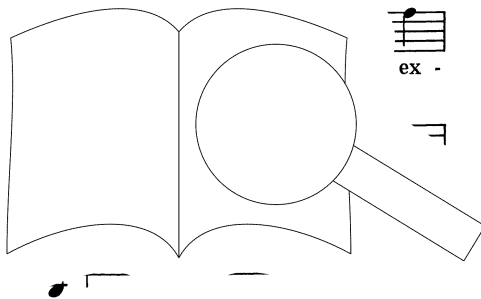

14

Musical score for measures 14-21. It includes vocal lines for Soprano (S), Alto (A), Tenor (T), and Bass (B), and a piano accompaniment (P). The lyrics are: O - san - na in ex - cel - sis, o - san - na in ex - cel - sis.

22

Musical score for measures 22-29. It includes vocal lines for Soprano (S), Alto (A), Tenor (T), and Bass (B), and a piano accompaniment (P). The lyrics are: O - san - na in ex - cel - sis, o - san - na in ex - cel - sis.

30

Musical score for measures 30-37. It includes vocal lines for Soprano (S), Alto (A), Tenor (T), and Bass (B), and a piano accompaniment (P). The lyrics are: o - san - na in ex - cel - sis, o - san - na in ex - cel - sis, in ex - cel - sis, o - san - na in ex - cel - sis.

74

Carus 40.630/03

PROBENPARTITUR  
 Ausgabequalität gegenüber Original evtl. gemindert • Evaluation Copy - Quality may be reduced • Carus-Verlag

# Benedictus

Andante

3

Musical score for the first system (measures 1-5). It features a vocal line and a piano accompaniment. The vocal line begins with a rest, followed by the lyrics "Be - ne-di-ctus qui ve-nit in no - mi-ne". The piano accompaniment includes a triplet of eighth notes and a trill. Dynamics include *mf* and *p*.

Musical score for the second system (measures 6-9). The vocal line continues with the lyrics "Be - ne - di-ctus qui ve - nit in no - mi-ne Domi-ni, in Do - mi-ni,". The piano accompaniment features a trill and continues with a melodic line. Dynamics include *mf* and *p*.

Musical score for the third system (measures 10-13). The vocal line continues with the lyrics "ni, he - qui ve - nit, be-ne-di - ctus qui ve - nit in". The piano accompaniment continues with a melodic line. Dynamics include *mf* and *p*.

Musical score for the fourth system (measures 14-17). The vocal line continues with the lyrics "be-ne-di-ctus - mi - ni, be-ne-di - ctus qui ve - nit in qui ve-nit, be-ne-di - ctus qui". The piano accompaniment continues with a melodic line. Dynamics include *mf* and *p*.

Musical score for the fifth system (measures 18-21). The vocal line continues with the lyrics "qui ve - nit in no - mi - ni, be-ne-di - ctus qui". The piano accompaniment continues with a melodic line. Dynamics include *mf* and *p*.

no - mi - ne\_ Do - mi - ni, be - ne - di - ctus qui ve - nit, qui ve - nit in no - mi - ne

no - mi - ne\_ Do - mi - ni, be - ne - di - ctus qui ve - nit, qui ve - nit in no - mi - ne

ve - nit in no - mi - ne\_ Do - mi - ni, be - ne - di - ctus qui ve - nit, qui ve - nit in no - mi - ne

ve - nit in no - mi - ne Do - mi - ni, be - ne - di - ctus qui ve - nit, qui ve - nit in no - mi - ne

Do - mi - ni,

Do - mi - ni,

Do - mi - ni,

Do - mi - ni,

qui ve - nit in

di - ctus qui ve - nit in

ne - di - ctus in

- ctus qui ve -

mi - ne

PROBENPARTITUR

Ausgabequalität gegenüber Original evtl. gemindert • Evaluation Copy - Quality may be reduced • Carus-Verlag

26

no - mi - ne Do - mi - ni,  
 no - mi - ne Do - mi - ni,  
 no - mi - ne Do - mi - ni,  
 Do - - - mi - ni, be - ni - di - ctus qui

26

*rf p rf p*

29

be - ne - di - ctus Do - mi -  
 ve - nit in no - mi - ne Do - mi - ni,

29

*tr*

33

be - ne - di - ctus in no - mi - ne Do - mi -  
 qui ve - nit in no - mi - ne  
 ni be - ne - di - ctus mi - ne  
 ui

*tr*



ni, qui ve - nit in no - mi - ne Do - mi - ni, be-ne-  
 Do - mi-ni, qui ve - nit in no - mi - ne Do - mi - ni, be-ne-di - ctus  
 Do - mi-ni, qui ve - nit in no - mi - ne Do - mi - ni, be-ne-di - ctus  
 ve - nit in no - mi - ne Do - mi - ni, be-ne-

*cresc.* *fp*

di - ctus qui ve - nit, be-ne - di  
 qui ve - nit in no - mi - ne Do - mi - ni, qui ve - nit in  
 qui ve - nit in no - mi - ne Do - mi - ni, be - di - ctus qui  
 di - ctus qui ve - nit in no - mi - ne Do - mi - ni, be-ne-di - ctus qui

no - mi - ni, be-ne-di - ctus qui ve - nit in  
 no - mi - ni, be-ne - di - ctus qui ve - nit in  
 ni - ne Do - mi - ni, qui ve - nit in  
 mi - ne Do - mi - ni, b qui

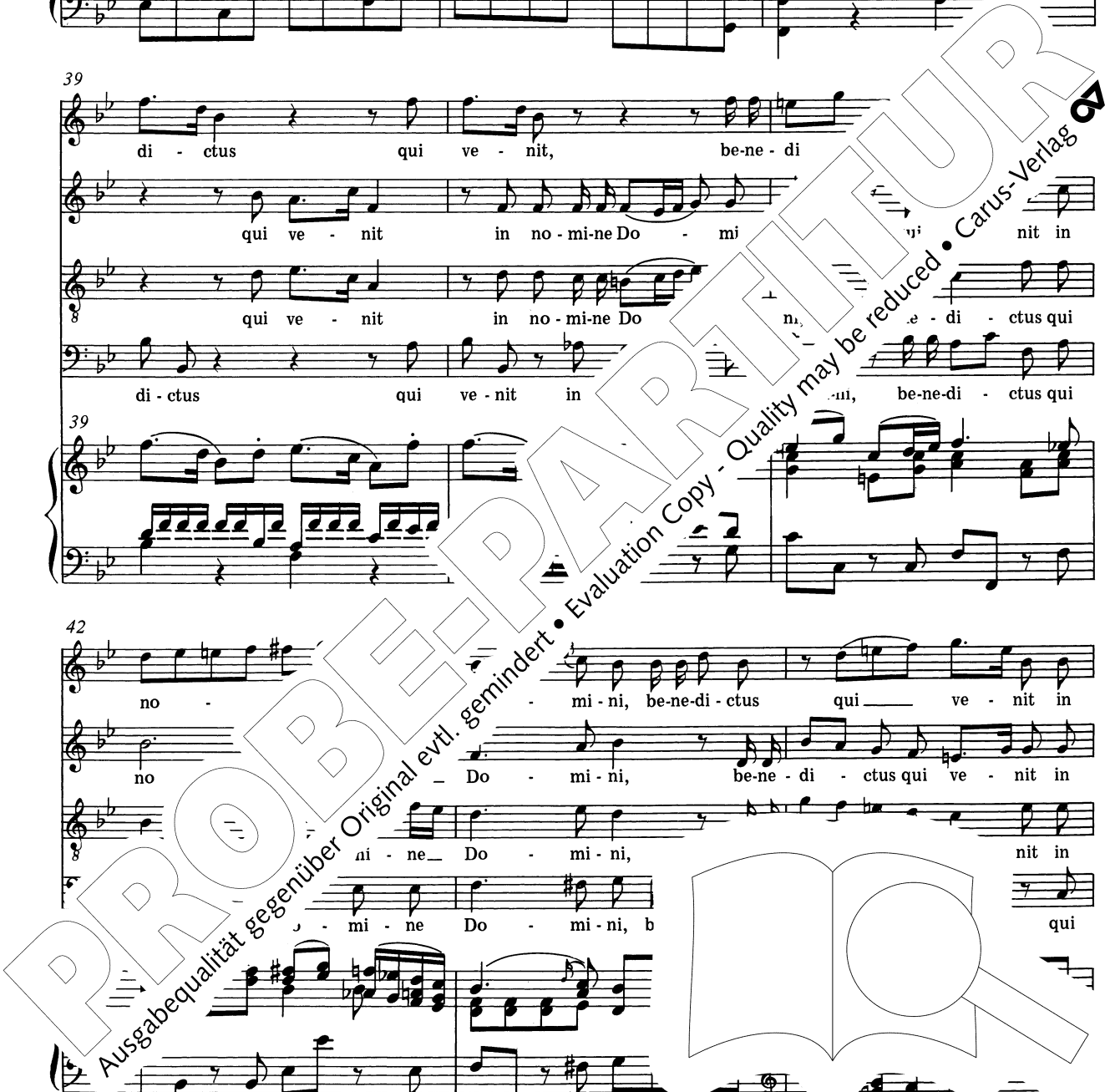

no - mi - ne, in no - mi - ne\_ Do - mi - ni, be - ne - di - ctus qui ve - nit, qui  
 no - mi - ne, in no - mi - ne Do - mi - ni, be - ne - di - ctus qui ve - nit, qui  
 no - mi - ne, in no - mi - ne Do - mi - ni, be - ne - di - ctus qui ve - nit, qui ve - nit  
 ve - nit in no - mi - ne Do - mi - ni, be - ne - di - ctus qui ve - nit, qui ve - nit

ve - nit, qui ve - nit in no - mi - ne Do - mi - ni.  
 ve - nit, qui ve - nit in no - mi - ne Do - mi - ni.  
 in no - mi - ne Do - mi - ni, in no - mi - ne Do - mi - ni.  
 in no - mi - ne Do - mi - ni, in no - mi - ne Do - mi - ni.

*dolce*

**Allegro**

**Tutti**

ex -

**A**

PROBENPARTITUR  
 Evaluation Copy - Quality may be reduced • Carus-Verlag

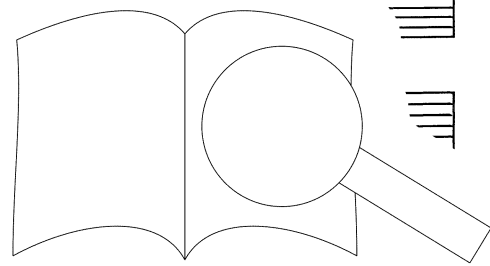

Tutti

0 - san - na

Tutti

O - san - na in - ex - cel - sis, o -

cel - sis, o - san - na in - ex - cel

in - ex - cel - sis, o - san - na

san - na in - ex - cel - sis, o

sis, in ex - cel

Tutti

O - san - na

sis, o - san - na in ex - cel - sis.

cel - sis, in ex - cel - sis.

san - na in ex - cel - sis.

o - san - na in

PROBEPARTITUR

Ausgabequalität gegenüber Original evtl. gemindert • Evaluation Copy - Quality may be reduced • Carus-Verlag

