

Johann Sebastian  
**BACH**

---

**Du Hirte Israel, höre**

O shield of Israel, hear us

BWV 104

Kantate zum Sonntag Misericordias Domini  
für Soli (TB), Chor (SATB)  
2 Oboen / Oboen d'amore, Taille (Englischhorn)  
2 Violinen, Viola und Basso continuo  
herausgegeben von Reinhold Kubik

Cantata for the 2nd Sunday after Easter  
for soli (TB), choir (SATB)  
2 oboes / oboes d'amore, taille (English horn)  
2 violins, viola and basso continuo  
edited by Reinhold Kubik  
English version by Vernon and Jutta Wicker

Stuttgarter Bach-Ausgaben · Urtext  
In Zusammenarbeit mit dem Bach-Archiv Leipzig

Partitur / Full score



---

Carus 31.104

# Inhalt

Vorwort	3
Foreword	4
1. Coro (SATB)	5
Du Hirte Israel, höre	
<i>O shield of Israel</i>	
2. Recitativo (Tenore)	40
Der höchste Hirte sorgt vor mich	
<i>Most high is he who cares for me</i>	
3. Aria (Tenore)	41
Verbirgt mein Hirte sich zu lange	
<i>When help my shepherd is detaining</i>	
4. Recitativo (Basso)	52
Ja, dieses Wort ist meiner Seelen Speise	
<i>This holy word delights my soul with pleasure</i>	
5. Aria (Basso)	53
Beglückte Herde, Jesu Schafe	
<i>O blessed flock, Christ is your shepherd</i>	
6. Choral	65
Der Herr ist mein getreuer Hirt	
<i>The Lord my faithful shepherd is</i>	

Zu diesem Werk liegt folgendes Aufführungsmaterial vor:  
Partitur (Carus 31.104), Studienpartitur (Carus 31.104/07),  
Klavierauszug (Carus 31.104/03), Chorpartitur (Carus 31.104/05),  
komplettes Orchestermaterial (Carus 31.104/19).

The following performance material is available:  
full score (Carus 31.104), study score (Carus 31.104/07),  
vocal score (Carus 31.104/03), choral score (Carus 31.104/05),  
complete orchestral material (Carus 31.104/19).

## Vorwort

Bach komponierte die Kantate *Du Hirte Israel, höre* BWV 104 für *Misericordias Domini*, den zweiten Sonntag nach Ostern 1724, der auf den 23. April fiel. Sie gehört somit zu Bachs erstem Leipziger Kantatenjahrgang,<sup>1</sup> den der Komponist gleich nach seinem Amtsantritt als Thomaskantor begonnen hatte und der für jeden Sonntag des Kirchenjahres und alle Festtage ein solches Werk vorsah. Bei 23 der insgesamt etwa 60 Kantaten dieses Jahrgangs griff Bach auf Werke seiner Weimarer und Köthener Zeit zurück, die er für die Leipziger Wiederaufführungen in unterschiedlich starkem Ausmaß bearbeitete. Die Textvorlagen für die Neukompositionen bezog er von unterschiedlichen Dichtern, die allerdings nur in einigen wenigen Fällen namhaft gemacht werden können.

Der unbekannt Dichter wurde durch die Kernaussage der Evangelienlesung für den Sonntag „Ich bin ein guter Hirte“ (Joh 10,12–16) dazu angeregt, den Kantatentext gänzlich der Hirtenmetaphorik zu verschreiben, die im Barock äußerst beliebt war. Außerdem hat er die Dichtung mit zahlreichen Bibelziten oder Anspielungen auf bestimmte Bibelstellen angereichert: Sie beginnt mit der Anrufung Gottes im Eingangschor „Du Hirte Israel, höre, ... erscheine ...“ (Ps 80,2) und widmet sich dann den Zweifeln eines Gläubigen, der sich selbst mit den Worten „Es wird ja alle Morgen des Hirten Güte neu“ (Klagelieder 3,23) und „Gott ist getreu“ (1. Kor 10,13) ermutigt (Nr. 2). Die Sehnsucht nach dem „Hirten“, dessen Worte dem lyrischen Ich „ein gläubig Abba“<sup>2</sup> (Röm 8,15 und Gal 4,6) entlocken, ist Thema der ersten Arie (Nr. 3). In der zweiten Hälfte des Werkes herrscht die Gewissheit vor, dass die „Schafe“ durch des „Hirten“ Wort bereits auf Erden einen Vorgeschmack auf den Himmel erlangen. Hierbei bleibt der Dichter ganz in der bildlichen Sprache und setzt die Vorwegnahme des Himmlischen mit der „Weide“, den Himmel selbst mit dem „Schafstall“ gleich (Nr. 4). Nach der Bitte um einen „sanften Todesschlaf“ (Nr. 5) endet die Kantate mit dem Psalmlied „Der Herr ist mein getreuer Hirt“ (Cornelius Becker 1598) (Nr. 6).

Bach gelingt es, die eindringlichen „Höre“-Rufe des Psalms und die ländliche Hirtenidylle im ruhigen, aber bewegten ersten Chorsatz miteinander zu vereinen. Das einleitende Instrumentalritornell sorgt mit seinem pastoralen Klang – mit durchgehenden Triolen und dreistimmigem Oboenchor, den Bach der Standardbesetzung Streicher und Basso continuo hinzugefügt – für das ländliche Kolorit des Satzes. Der Chorsatz weist drei homophone und zwei fugierte Abschnitte auf, die einander abwechseln, wobei erstere durch gelegentliche Aufteilung in Stimmpaare und die Fugen durch „Höre“-Einwürfe aufgelockert werden.

Es folgen zwei Satzpaare, bestehend aus Secco-Rezitativ und Arie, von denen das erste dem Tenor, das zweite dem

Bass zugeteilt ist. Die Tonsprache des ersten Rezitativs „Der höchste Hirte sorgt vor mich“ vermittelt entgegen dem tröstenden Charakter des Textes eine melancholische Stimmung. In der Arie „Verbirgt mein Hirte sich zu lange“ mit zwei Oboi d'amore werden die starken Emotionen Sehnsucht, Angst und Verzweiflung lebendig und glaubwürdig in Musik umgesetzt. Dies erreicht Bach durch ausgedehnte Haltetöne auf „lange“, harmoniefremde Einfärbung der Worte „allzu bange“ und große Intervallsprünge bei „Mein Mund schreit“.

Mit den Worten des Rezitativs „Ja, dieses Wort ist meiner Seelen Speise“ läutet der Bass die zweite, optimistische Hälfte der Kantate ein. Die *Dacapo*-Arie „Beglückte Herde, Jesu Schafe“, begleitet von Streichern, einer Oboe und Basso continuo, greift den pastoralen Klang des 1. Satzes auf. Inhaltlich stehen die beiden klanglich ähnlichen Sätze zueinander wie alttestamentliche Anrufung und neutestamentliche Erfüllung.<sup>3</sup> Bemerkenswert ist die Vertonung des „sanften Todesschlafes“ durch Hinabführen des Sängers zum großen F und Haltetönen von bis zu zwei Takten Länge.

Das Werk endet mit dem schlichten vierstimmigen Chorsatz „Der Herr ist mein getreuer Hirt“ über die Melodie von Nicolaus Decius' „Allein Gott in der Höh sei Ehr“ (1523).

Die Kantate ist in 12 Originalstimmen überliefert. Die autographe Partitur ist verschollen. In einer kritischen Edition wurde die Kantate zuerst 1876 von Wilhelm Rust im Rahmen der Gesamtausgabe der Bach-Gesellschaft vorgelegt (BG 23). Innerhalb der Neuen Bach-Ausgabe wurde sie 1988 von Reinmar Emans ediert (NBA I/11.1).

Heidelberg, Februar 2017

Karin Wollschläger

<sup>1</sup> Alfred Dürr, *Zur Chronologie der Leipziger Vokalwerke J. S. Bachs. Zweite Auflage: Mit Anmerkungen und Nachträgen versehener Nachdruck aus Bach-Jahrbuch 1957*, Kassel 1976, S. 14 und 69.

<sup>2</sup> Abba ist aramäisch und bedeutet „Vater“.

<sup>3</sup> Alfred Dürr, *Johann Sebastian Bach. Die Kantaten*, Kassel etc. 92005, S. 342.

## Foreword

Bach composed the cantata *Du Hirte Israel, höre* (O shield of Israel, hear us) BWV 104 for *Misericordias Domini*, the second Sunday after Easter 1724, which fell on 23 April. It is thus part of the first Leipzig annual cycle of cantatas<sup>1</sup> which Bach began immediately after taking up the position as Kantor at St. Thomas's church in Leipzig, aiming to provide a sacred cantata for every Sunday and Feast Day of the church year. For 23 of the altogether approximately 60 cantatas of this annual cycle, Bach fell back on works from his time in Weimar and Köthen, revising them to a greater or lesser extent for the renewed performances in Leipzig. The text models for the new compositions were taken from various poets who, however, can seldom be identified.

The unknown poet of the present cantata was inspired by the core statement of the gospel reading for the Sunday "I am the good shepherd" (John 10:11–16) to set the entire text of the cantata in the metaphor of the shepherd, which was extremely popular in the Baroque era. He also enriched the poetry with numerous Bible quotations or references to certain Bible passages. It begins with the invocation of God in the opening chorus "Du Hirte Israel, höre, ... erscheine..." (O shield of Israel, hear us, ... shine forth, Lord) (Ps 80:2) and then concentrates in no. 2 on the doubts of a believer who encourages himself with the words "Es wird ja alle Morgen des Hirtens Güte neu" (Each morning, his great mercies the shepherd grants anew) (Lam 3:23) and "Gott ist getreu" (God is most true) (1 Cor 10:13). The subject of the first aria (no. 3) is the yearning for the "shepherd" whose words elicit "ein gläubig Abba" (a faithful Abba)<sup>2</sup> from the lyrical "self" (Rom 8:15 and Gal 4:6). The second half of the cantata is suffused with the certainty that the "sheep" on earth are already granted an intimation of heaven, thanks to the Word of the "shepherd." Here, the poet remains entirely within the metaphor, equating the intimation of heaven with the "meadow" and heaven itself with the "sheepfold" (no. 4). After a plea for "sanften Todesschlaf" (Death's sweet slumber) in no. 5, the cantata closes with the psalm chorale "Der Herr ist mein getreuer Hirt" (The Lord my faithful shepherd is) (Cornelius Becker 1598) (no. 6).

Bach succeeds in merging the emphatic "Höre" cries of the psalm with the bucolic idyll in the first choral movement, which is tranquil and yet animated. With its pastoral sound, the introductory instrumental ritornello – with continuous triplets and a three-part choir of oboes which Bach added to his standard scoring of strings and basso continuo – evokes this movement's bucolic atmosphere. The choral setting contains three homophonic and two fugal sections which alternate with one another; the former are interspersed with occasional divisions into pairs of

voices, and the fugues are punctuated by interjections of "Höre."

The following two pairs of movements consists of a secco recitative and an aria, the first being given to the tenor and the second to the bass. The musical language of the first recitative communicates a melancholy atmosphere, in spite of the comforting character of the text "Der höchste Hirte sorgt vor mich" (Most high is he who cares for me). In the aria "Verbirgt mein Hirte sich zu lange" (When help my shepherd is detaining) with its two oboi d'amore, the intense emotions of yearning, fear and despair are rendered into music in a vivid and convincing manner. Bach achieves this by means of extended held notes on "lange" (detaining), by dissonant coloration of the words "allzu bange" (I am fearing), and by large interval leaps on "Mein Mund schreit" (My voice cries).

The second, optimistic half of the cantata is introduced by the bass recitative with the words "Ja dieses Wort ist meiner Seelen Speise" (This holy word delights my soul with pleasure). The da capo aria "Beglückte Herde, Jesu Schafe" (O blessed flock, Christ is your shepherd) is accompanied by strings, one oboe and basso continuo; it returns to the pastorale sound of the first movement. In terms of meaning, the two movements, so similar in sonority, are related like an Old Testament invocation and a New Testament fulfillment.<sup>3</sup> The setting of the "sanfter Todesschlaf" is remarkable: the singer is led down to the low *F* with held notes of up to two measures in length.

The work closes with the simple four-part chorale setting "Der Herr ist mein getreuer Hirt" on the melody of Nicolaus Decius's "Allein Gott in der Höh sei Ehr" (1523). The cantata is extant in 12 original parts; the autograph score is lost. The first critical edition of this cantata was presented in 1876 by Wilhelm Rust within the framework of the complete edition of the Bach-Gesellschaft (BG 23). In 1988, Reinmar Emans edited this work for the Neue Bach-Ausgabe (NBA I/11.1).

Heidelberg, February 2017  
Translation: David Kosviner

Karin Wollschläger

<sup>1</sup> Alfred Dürr, *Zur Chronologie der Leipziger Vokalwerke J. S. Bachs. Zweite Auflage: Mit Anmerkungen und Nachträgen versehener Nachdruck aus Bach-Jahrbuch 1957*, Kassel 1976, pp. 14 and 69.

<sup>2</sup> Abba is Aramaic and means "father."

<sup>3</sup> Alfred Dürr, *Johann Sebastian Bach. Die Kantaten*, Kassel etc., 1995, p. 342.

# Du Hirte Israel, höre

*O shield of Israel, hear us*

BWV 104

Johann Sebastian Bach

1685–1750

## 1. Coro

Oboe I  
*staccato*

Oboe II  
*staccato*

Taille  
*staccato*

Violino I

Violino II

Viola

Soprano

Alto

Tenore

Basso

Bassc

6  
4

7  
5  
4

8  
3

7  
4  
2

Aufführungsdauer/Duration: ca. 17 min.

© 1986/1992 by Carus-Verlag, Stuttgart – CV 31.104

Vervielfältigungen jeglicher Art sind gesetzlich verboten./Any unauthorized reproduction is prohibited by law.

Alle Rechte vorbehalten / All rights reserved / 2017 / Printed in Germany / www.carus-verlag.com

by Reinhold Kub.  
Generalbassaussetzung: Paul Horn  
English version by  
Vernon and Jutta Wicker

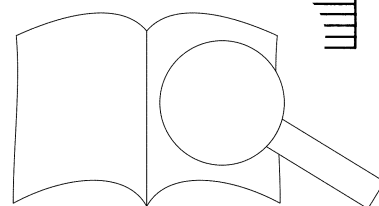

4

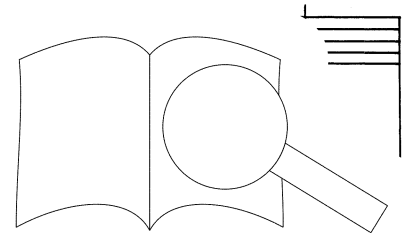

7 4 6 5 6 5 7  
3 4 3 4 3 4 2

8

8  
3

6

7  
#

6  
4  
2

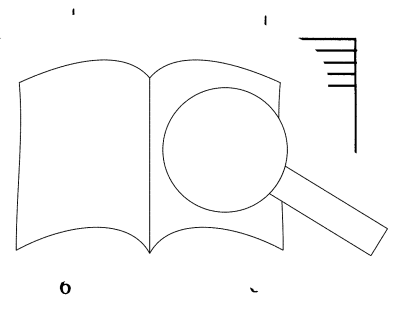

PROBEPARTITUR  
 Ausgabequalität gegenüber Original evtl. gemindert • Evaluation Copy - Quality may be reduced • Carus-Verlag



Musical notation system 1, measures 1-4. Treble clef contains a melodic line with eighth and sixteenth notes. Bass clef contains a bass line with quarter notes.

Musical notation system 2, measures 5-8. Treble clef contains a melodic line with eighth and sixteenth notes. Bass clef contains a bass line with quarter notes.

Musical notation system 3, measures 9-12. Treble clef contains a melodic line with eighth and sixteenth notes. Bass clef contains a bass line with quarter notes.

Musical notation system 4, measures 13-16. Treble clef contains a melodic line with eighth and sixteenth notes. Bass clef contains a bass line with quarter notes.

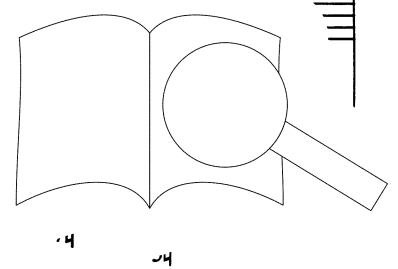

PROBEPARTITUR  
 Ausgabequalität gegenüber Original evtl. gemindert • Evaluation Copy - Quality may be reduced • Carus-Verlag

7 6 7 7 6 7 7 6 7

6 ,

PROBEPARTITUR  
 Ausgabequalität gegenüber Original evtl. gemindert • Evaluation Copy - Quality may be reduced • Carus-Verlag

24

Du Hir - te  
O shield of

du Hir - te  
O shield of

Du H' - el,  
O shieu - el,

du Hir - te  
O shield of

te Is - ra - el,  
of Is - ra - el,

du Hir - te  
O shield of

Hir - te Is - ra - el,  
shield of Is - ra - el,

du Hir - te  
O shield of

9 6 6 6 5 4 3 6 5 4

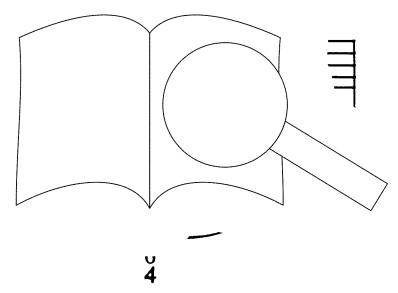

Is - ra - el, hö - re, re,  
 Is - ra - el, hear us, us,

Is - ra - el, hö - re,  
 Is - ra - el, hear us, us,

Is - ra - el, re, hö - re,  
 Is - ra - el, us, hear us, us,

Is - hö - re, hö - re,  
 hear us, hear us,

5 3                      6 4

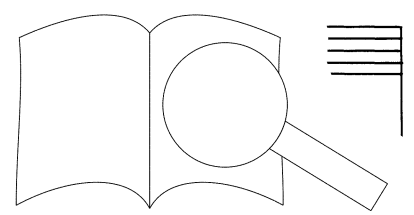

4 2                      5 3                      4 2

PROBEPARTITUR  
 Ausgabqualität gegenüber Original evtl. gemindert • Evaluation Copy - Quality may be reduced • Carus-Verlag

du Hir - te Is - ra - el, hö - re,  
O shield of Is - ra - el, hear us

du Hir - te Is - ra - el,  
O shield of Is - ra - el,

du Hir - te  
O shield

du  
- el, hö - re,  
hear us,

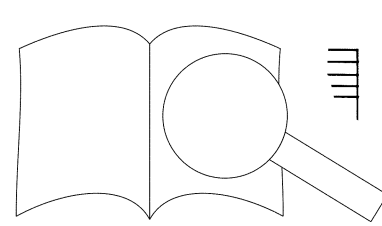

PROBENPARTITUR  
Ausgabequalität gegenüber Original evtl. gemindert • Evaluation Copy - Quality may be reduced • Carus-Verlag

hö - re, du Hir - re,  
hear us, O sh - re,

hö - re, - ra - el, hö - re,  
hear us, Is - ra - el, hear us!

hö - re, di - - ra - el, hö - re,  
hear us, - ra - el, hear us!

hö e, of Is - - ra - el, hö - re,  
Is - - ra - el, hear us!

5 6 7  
3 4 4  
2 2

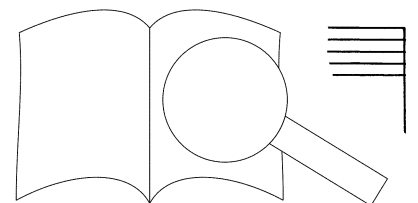

PROBEPARTITUR  
Ausgabequalität gegenüber Original evtl. gemindert • Evaluation Copy - Quality may be reduced • Carus-Verlag

der\_ du Jo - seph hü - test wie  
 You give Jo - seph guid-ance

der du Jo - seph  
 You give Jo - seph

der \_\_\_\_\_ di \_\_\_\_\_ test wie der Scha -  
 You \_\_\_\_\_ \_\_\_\_\_ ance like a shep -

der \_\_\_\_\_ hü - test wie der Scha -  
 y \_\_\_\_\_ seph guid - ance like a shep -

6 7 # 6 4+ 2

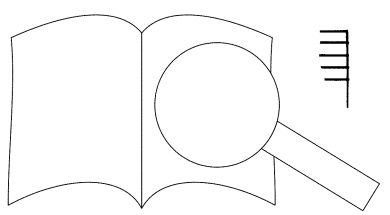

PROBEPARTITUR  
 Ausgabqualität gegenüber Original evtl. gemindert • Evaluation Copy - Quality may be reduced • Carus-Verlag

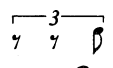

First system of musical notation with three staves (treble, alto, bass clefs).

Second system of musical notation with three staves.

Third system of musical notation with three staves and lyrics:   
- - - - - fr - - - - - ne, der  
- - - - - th, Lord, you

Fourth system of musical notation with three staves and lyrics:   
- - - - - er - schei - ne, der du  
- - - - - shine forth, Lord, you who

Fifth system of musical notation with three staves and lyrics:   
- - - - - fe, er - schei - ne, der  
- - - - - herd; shine forth, Lord, you

Sixth system of musical notation with three staves and lyrics:   
- - - - - fe, er - schei - ne, der  
- - - - - herd; shine forth, Lord, you

Seventh system of musical notation with three staves.

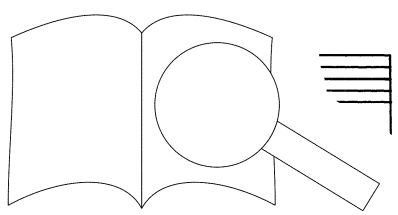

8 7 6 6 7 5 6 5b 9

PROBENPARTITUR  
Ausgabequalität gegenüber Original evtl. gemindert • Evaluation Copy - Quality may be reduced • Carus-Verlag



du sit - zest  
 who dwell a jim!

sit - zest ü - ber - ru - bim.  
 dwell a - bove the c. - u - bim!

du sit - - ru - bim.  
 who dwell - u - bim!

- zest ü - ber Che - ru - bim.  
 a - bove the cher - u - bim!

3 8 6 6 6 4 3 5 6

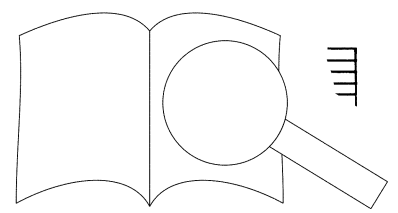

PROBEPARTITUR  
 Ausgabqualität gegenüber Original evtl. gemindert • Evaluation Copy - Quality may be reduced • Carus-Verlag

Du Hir - ra - el,  
 O - ra - el,

u te Is - ra - el,  
 of Is - ra - el,

Hir - te of Is - ra - el,  
 shield of Is - ra - el,

Du Hir - te of Is - ra - el,  
 O shield of Is - ra - el,

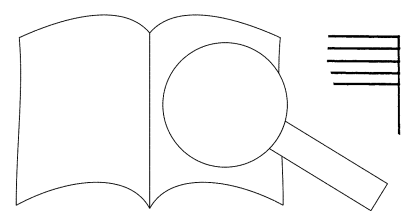

7 8 7 5 6 6 7 3  
 4 3 4 3 4 4 4 3  
 2 3 2 3 4 4 3

PROBEPARTITUR  
 Ausgabqualität gegenüber Original evtl. gemindert • Evaluation Copy - Quality may be reduced • Carus-Verlag

du Hir - te Is - ra - el, hö - re,  
O shield of Is - ra - el, hear us,

du Hir - te Is - ra - el, h  
O shield of Is - ra - el, hea,

du Hir - te Is - - - ra - el,  
as, O shield of Is - - - ra - el,

hö - re, du Hir - te Is - - - ra - el,  
hear us, O shield of Is - - - ra - el,

6  
4

5  
3

6  
4  
2

r  
4  
2

PROBENPARTITUR  
Ausgabequalität gegenüber Original evtl. gemindert • Evaluation Copy - Quality may be reduced • Carus-Verlag

hö - re,  
hear us!

hö - re,  
hear us!

hö - re,  
hear us!

hü - test wie der Scha -  
guid - ance like a shep -

hö

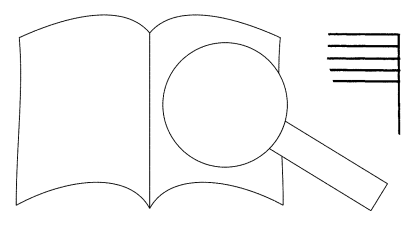

PROBEPARTITUR  
Ausgabequalität gegenüber Original evtl. gemindert • Evaluation Copy - Quality may be reduced • Carus-Verlag

Jo - seph hü - test wie der  
 Jo - seph guid - ance like a

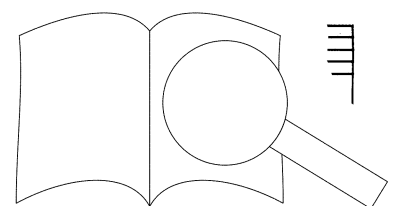

8  
#

7

6  
4  
2

7

7

Scha -  
shep -

der\_ du  
You give

- fe, er - schei - ne, er -  
- herd; shine forth, Lord, shine

PROBEPARTITUR  
Ausgabequalität gegenüber Original evtl. gemindert • Evaluation Copy - Quality may be reduced • Carus-Verlag

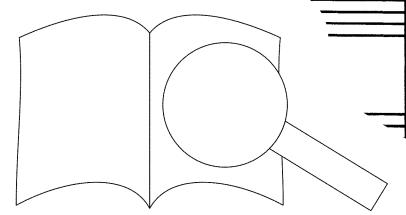

\*) Ausführung stets:  $\overline{7 \ 7 \ 7}$   
To be performed:

Jo - seph hü - test wie der Scha -  
 Jo - seph guid - ance like a shep -

: : : : - fe, er -  
 : : : : - herd; shine

schei - ne, ne, er - schei - ne, er -  
 forth, Lord, Lord, shine forth, Lord, shine

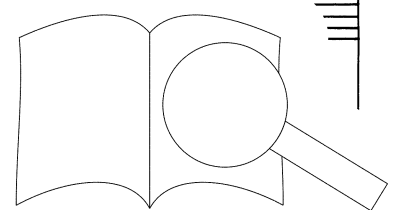

PROBEPARTITUR  
 Ausgabequalität gegenüber Original evtl. gemindert • Evaluation Copy - Quality may be reduced • Carus-Verlag

schei - ne, er - s er - schei - ne, er -  
 forth, Lord, shine fo. ne shine forth, Lord, shine

schei - ne, ne, er - schei - ne, er -  
 forth, Lord Lord, shine forth, Lord, shine

give Jo - seph hü - test wie der Scha -  
 Jo - seph guid - ance like a shep -

6 6 6 7 6  
 2

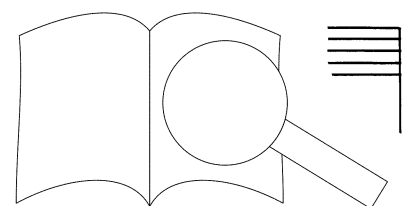



- - fe, er - schei - ne, ne, er -  
 - - herd; shine forth, Lord Lord, shine

schei - ne, er - sc<sup>t</sup> - schei - ne, er -  
 forth, Lord, shine fo, nine forth, Lord, shine

schei - ne, er - schei - ne, er -  
 forth, Lord, shine forth, Lord, shine

- - - - -

8 7 $\frac{1}{2}$  6 6 7

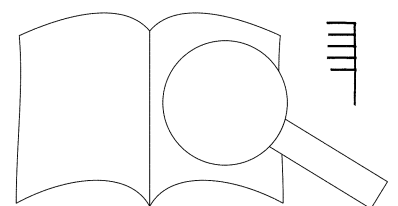

PROBENPARTITUR  
 Ausgabequalität gegenüber Original evtl. gemindert • Evaluation Copy - Quality may be reduced • Carus-Verlag

schei - ne, er - schei -  
 forth, Lord, shine forth, *tor*

*u* Hir - - - te  
 O shield of

schei - ne, er  
 forth, Lord, shine

du Hir - te  
 O shield of

schei - ne,  
 forth, Lo'

ne,  
 Lord,

du Hir - - - te  
 O shield of

- fe,  
 - herd;

du Hir - te  
 O shield of

7 9 8

5 3 6 4

PROBEPARTITUR  
 Ausgabqualität gegenüber Original evtl. gemindert • Evaluation Copy - Quality may be reduced • Carus-Verlag

Is - ra - el,                      du Hir -                      - el,  
 Is - ra - el,                      O shield                      - el,

Is - ra - el,                      Is - ra - el,                      Is - ra - el,  
 Is - ra - el,                      Is - ra - el,

Is - ra - el,                      - - - te                      Is - ra - el,  
 Is - ra - el,                      shield of                      Is - ra - el,

Is - ra - el,                      du Hir -                      te                      Is - ra - el,  
 Is                      O shield of                      Is - ra - el,

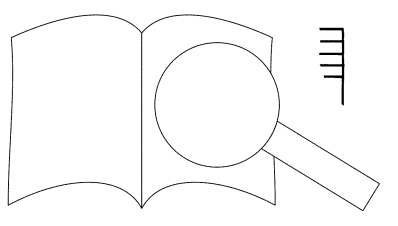

PROBEPARTITUR  
 Original evtl. gemindert • Evaluation Copy - Quality may be reduced • Carus-Verlag

hö - re, hö - re, ir - te Is - ra - el,  
 hear us, hear us! shield of Is - ra - el,

hö - re, du Hir - te Is - ra - el,  
 hear us, O shield of Is - ra - el,

hö - re, du Hir - te Is - ra - el,  
 hear us, O shield of Is - ra - el,

hö hö - re, du Hir - te Is - ra - el,  
 hear us! O shield of Is - ra - el,

PROBEPARTITUR  
 Ausgabqualität gegenüber Original evtl. gemindert • Evaluation Copy - Quality may be reduced • Carus-Verlag

hö - re, re, du Hir - te  
hear us! us, O shield of

hö - re, hö - re, du Hir - te  
hear us! Hear us, O shield of

hö - re, - te Is - ra - el, hö - re,  
hear us! shield of Is - ra - el, hear us,

hö - re, du Hir - te Is - ra - el, hö - re,  
he O shield of Is - ra - el, hear us,

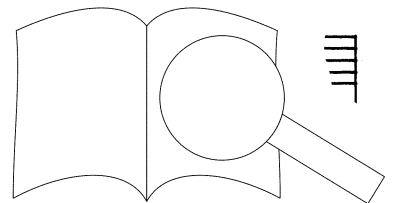

PROBEPARTITUR  
Ausgabequalität gegenüber Original evtl. gemindert • Evaluation Copy - Quality may be reduced • Carus-Verlag

Is - - - ra - el, hö - re,  
 Is - - - ra - el, hear -

Is - - - ra - e  
 Is - - - ra - el,

du Hir - re,  
 O shiel - ar - us!

h e - el, hö - re, der du Jo - seph hü - test wie der  
 - ra - el, hear us! You give Jo - seph guid - ance like a

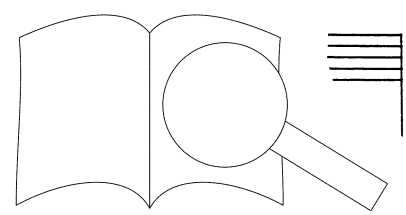

PROBEPARTITUR  
 Ausgabequalität gegenüber Original evtl. gemindert • Evaluation Copy - Quality may be reduced • Carus-Verlag

hö - re, re,  
Hear us! us!

hö - re, hö - re,  
Hear us! Hear us!

hö - re, hö - re, der du  
Hear us! Hear us! You give

Scha -  
st

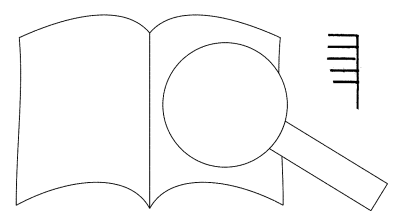

6  
4  
2      6

PROBEPARTITUR  
Ausgabequalität gegenüber Original evtl. gemindert • Evaluation Copy - Quality may be reduced • Carus-Verlag

hö -  
Hear us

Jo - seph hü -  
Jo - seph gui -

gemindert. - a - - - -  
shep - - - -

- fe, er -  
- herd; shine

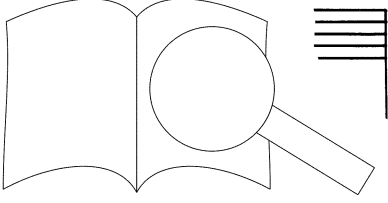

7

7

PROBEPARTITUR  
Ausgabequalität gegenüber Original evtl. gemindert. Evaluation Copy - Quality may be reduced. Carus-Verlag



hö - re, re,  
Hear us! us!

hö - re, der du Jo der Scha -  
Hear us! You give Jo a shep -

- - - - -

schei - schei - ne, er - schei - ne, er -  
forth forth, Lord, shine forth, Lord, shine

6 6 6 7 6  
4 2

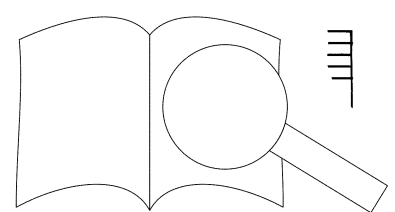

PROBEPARTITUR  
Ausgabequalität gegenüber Original evtl. gemindert • Evaluation Copy - Quality may be reduced • Carus-Verlag



Scha -  
shep -

ne - schei - ne, er -  
forth, Lord, shine

schei - ne,  
forth, Lord,

er - schei - ne, er -  
shine forth, Lord, shine

schei -  
forr' ne schei - ne,  
ne forth, Lord,

er - schei - ne, er -  
shine forth, Lord, shine

8

7

8

7h

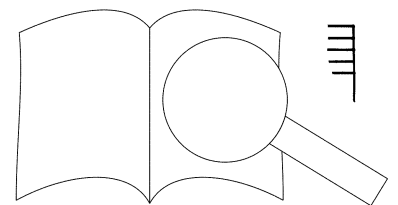

6h

- - - - - er - schei - ne, er -  
 shine forth, Lord, shine

schei - ne, er - schei - ne, er -  
 forth, Lord, shine forth, shine forth, Lord, shine

schei - ne, er - schei - ne, er -  
 forth, Lord, shine forth, Lord, shine forth, Lord, shine

schei - ne, er - schei - ne, er -  
 forth, Lord, shine forth, Lord, shine forth, Lord, shine

6 7 6 7b 6b 7 6

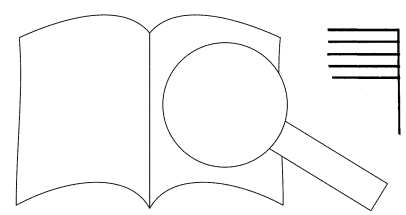

5

PROBEPARTITUR

Ausgabequalität gegenüber Original evtl. gemindert • Evaluation Copy - Quality may be reduced • Carus-Verlag

schei - ne, er - schei - ne, der du Jo wie der Scha -  
 forth, Lord, shine forth, Lord. You giv - e like a shep -

schei - ne, er - schei - ne, Jo - seph hü - test wie der  
 forth, Lord, shine forth, e Jo - seph guid - ance like a

schei - ne, der du Jo - seph hü - test wie der  
 forth, Lord, You give Jo - seph guid - ance like a

schei - ne, der du Jo - seph hü - test wie der  
 forth, Lord. You give Jo - seph guid - ance like a

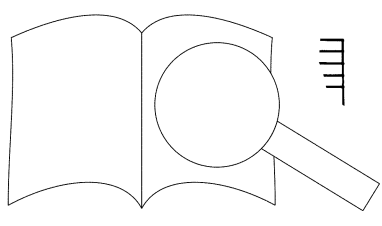

7 6 7 6 7 8 7 6

PROBEPARTITUR  
 Original evtl. gemindert • Evaluation Copy - Quality may be reduced • Carus-Verlag



schei - ne, der du sit - zest ü - - ru - bim.  
 forth, Lord, you who dwell a - - u - bim!

schei - ne, der du - zest ü - ber Che - ru - bim.  
 forth, Lord, you who a - bove the cher - u - bim!

schei - ne, der. - ü - ber Che - - ru - bim.  
 forth, Lord, y' a - bove the cher - - u - bim!

schei - du sit - - zest ü - ber Che - ru - bim.  
 fort' - who dwell a - bove the cher - u - bim!

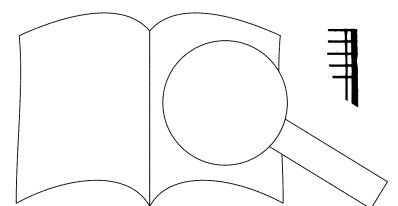

PROBENPARTITUR  
 Ausgabequalität gegenüber Original evtl. gemindert

Evaluation Copy - Quality may be reduced • Carus-Verlag

## 2. Recitativo



Tenore

Der höch - ste Hir - te sorgt vor\*) mich, was nüt - zen mei - ne  
 Most high is he who cares for me, what good are all my

Basso continuo

7  
4  
2  
6

3

Sor - gen? Es wird ja al - le Mor - gen des Hir  
 wor - ries? Each morn - ing his great mer - cies the sh

# 6 5h

5

neu. Mein Herz, so  
 new. My heart, h

ante  
 Gott ist ge - treu,  
 God is most true,

6 8 6 6

7

Gott ist ge - treu.  
 God is most true.

7 6 6  
4+ 4

\*) für

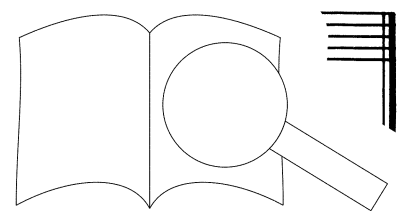
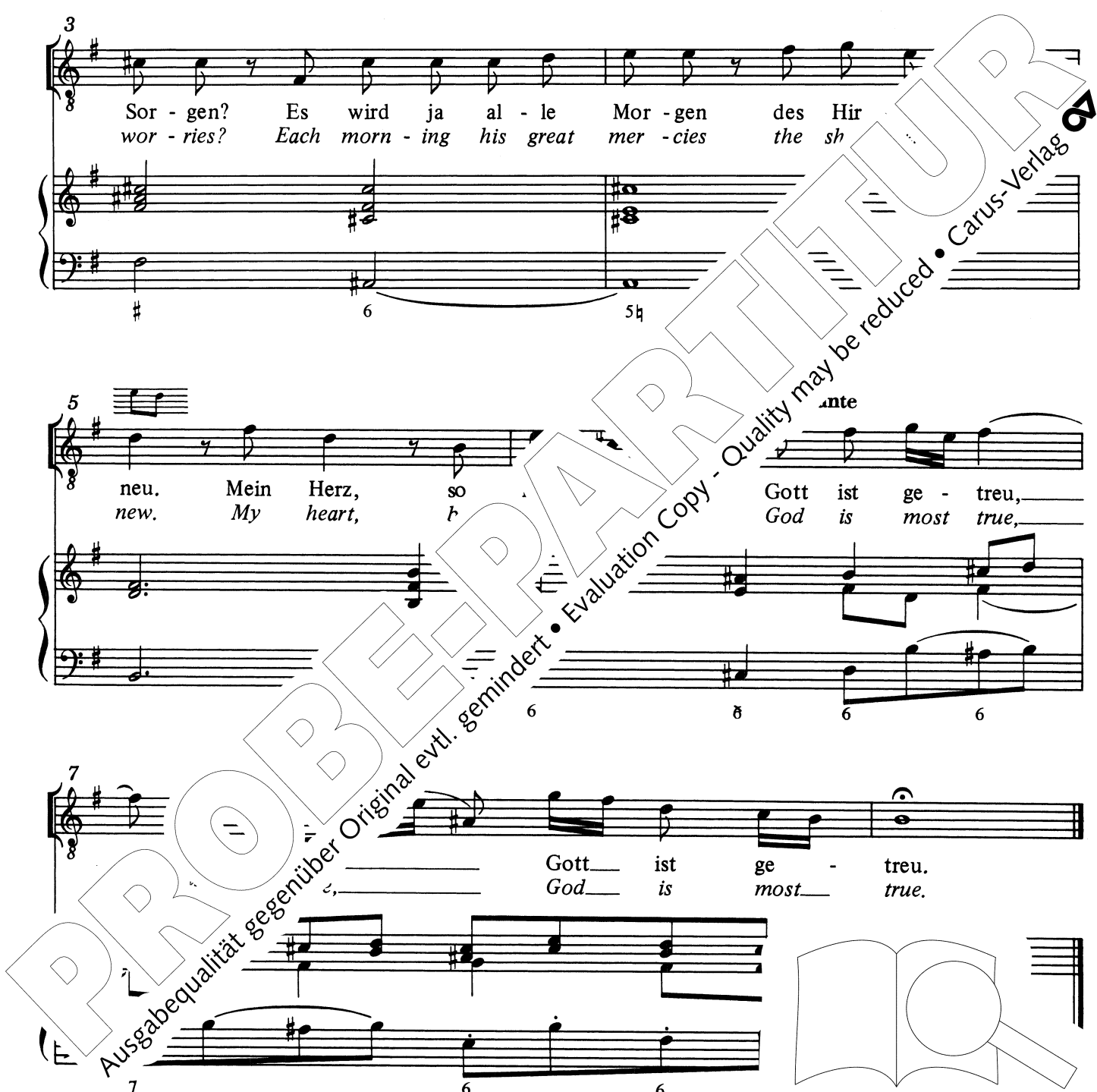



### 3. Aria

Oboe d'amore I

Oboe d'amore II

Tenore

Basso continuo

3

6

Ver - birgt mein Hir - te — sich zu lan - - - ge, —  
 When help my — shep - herd is de - tain - - - in

9

ver - birgt mein Hir - te —  
 when help my — shep - herd

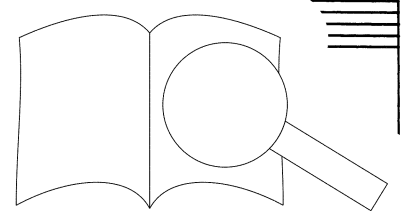

PROBEPARTITUR

Ausgabequalität gegenüber Original evtl. gemindert • Evaluation Copy - Quality may be reduced • Carus-Verlag

12

sich zu lan - ge, - zu lan -  
 is de - tain - ing, - de - tain -

6 6 5 # 6 9 8 7 6 8 6 5

15

- ge, Wü-ste all - zu - ban -  
 - in! des - ert I am - fear -

9 6 7 6 6 5 4 7 6 5 9 6 5 6 #

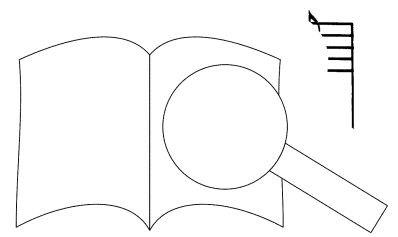

18

-ge, mein schwa - cher  
 -ing, my weak - oned

7 7 6 5 9<sub>h</sub> 8 5 7 5 6 6

21

Schrit'  
 step

ort, eilt den - noch fort.  
 still, moves on - ward still.

6 6 7<sub>h</sub> 4 # 8 1

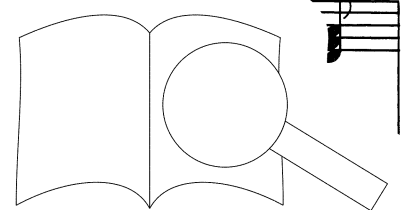

Mein

7 # 9 8 7 7 6 5 # 5 6

Mund  
voice

schreit nach dir, mein Mund schreit, mein Mund  
 cries for you, my voice cries, my voice

7 # 5 7 5 6 6 5 # 6 6

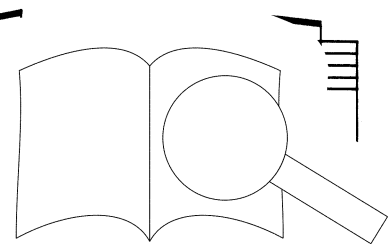

29

schreit — nach dir, und du, mein Hir - te, wirkst in mir, und du, —  
 cries — for you, and you, my shep-herd, give to me, and you, —

32

— r — mir ein gläu - big Ab - ba, ein gläu - big  
 — o — me a faith - ful Ab - ba, a faith - ful

PROBEPARTITUR  
 Ausgabqualität gegenüber Original evtl. gemindert • Evaluation Copy - Quality may be reduced • Carus-Verlag

35

Musical notation for measures 35-37. The vocal line is in treble clef with a key signature of one sharp (F#). The piano accompaniment is in bass clef. Dynamics include *f* and *tr* (trill).

Ab - ba durch \_\_\_\_\_ dein \_\_\_\_\_ Wort.  
 Ab - ba through \_\_\_\_\_ your \_\_\_\_\_ word.

Ver -  
 when

Piano accompaniment for measures 35-37. The right hand is in treble clef and the left hand is in bass clef. Fingerings are indicated with numbers 1-5. Dynamics include *f*.

6 4 2  
 6 5 7 4 3  
 5

38

Musical notation for measures 38-39. The vocal line is in treble clef. Dynamics include *p*.

birgt  
 help

zu lan -  
 de - tain -

Piano accompaniment for measures 38-39. The right hand is in treble clef and the left hand is in bass clef. Dynamics include *p*. A large watermark 'PROBEEPARTITUR' is overlaid diagonally across the page.

6 6 6 6 6 5 6

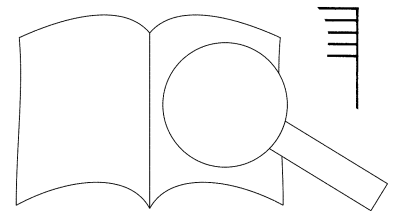

5 6 5

41

41

*f* *p*

ge, ver -  
ing, when

*f*

9 8 6 7 6 7 5 9 7 8 6 7 #

44

44

birg sich zu lan -  
hel, is de - tain -

*p*

# 6 6 5# 7# 7 #

7 8 6 5



ge, — macht mir — die —  
 ing, — when in — this .

7<sub>h</sub> 6<sub>h</sub> 7<sub>h</sub> 6 9<sub>h</sub> 7<sub>h</sub>

Wü - ste  
 des - ert

ban -  
 fear -

6<sub>h</sub> b 7<sub>b</sub> 6 5 9<sub>h</sub> 6<sub>h</sub> 5 7<sub>h</sub> 7<sub>h</sub> 7 7<sub>h</sub> 6<sub>h</sub> 5

PROBEPARTITUR  
 Ausgabqualität gegenüber Original evtl. gemindert • Evaluation Copy - Quality may be reduced • Carus-Verlag

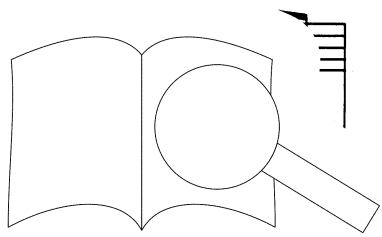

Musical notation for measures 52-54, including vocal and piano parts.

- ge, mein schwa-cher Schritt eilt  
 - ing, my weak-ened step moves

Piano accompaniment for measures 52-54 with fingerings: 9# 8 7 7 6 7 8 6 5 6 5 6

Musical notation for measures 55-57, including vocal and piano parts.

schwacher Schritt eilt den - noch fort.  
 weak-ened step moves on - ward still.

Piano accompaniment for measures 55-57 with fingerings: 9 6 6 6 8 6 7 6 2 4 4 5 4 5

58

61

7 9 8 7 6 5 # 6 4 5

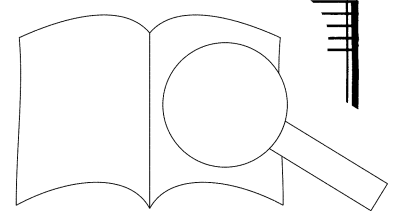

PROBEPARTITUR  
 Ausgabequalität gegenüber Original evtl. gemindert • Evaluation Copy - Quality may be reduced • Carus-Verlag

# 4. Recitativo

Basso

Ja, die - ses Wort ist mei - ner See - len Spei - se, ein  
*This ho - ly word de - lights my soul with plea - sure, is*

Basso continuo

3

Lab - sal mei - ner Brust, die Wei - de, die ich mei - ne Lust, des H: r's  
*quick - en - ing to me; a mead - ow that grants joy and rest, a*

5

Vorschmack, ja, mein al - les hei - ße. Ach! r, n Hir - te, uns  
*fore - taste, yes, my high - est trea - sure. O n - ed shep - herd, the*

8

Ar - me und V laß den Weg nur bald ge - en - det  
*lone - ly and that this path would soon come to its*

10

füh - re uns in dei - nen Schaf - stall  
*and lead us all in - to your fold, O*

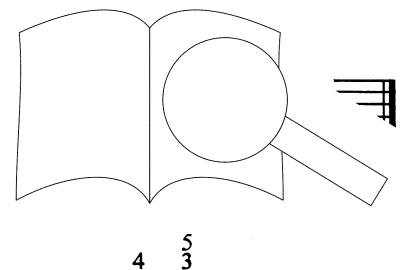

# 5. Aria

Violino I  
Oboe d'amore I

Violino II

Viola

Basso

Basso continuo

7 8 7 8 6  
4 3 4 3  
2 2 2 3 8 7 4 2

8 6 6 7 # 6 8 6  
5 3 6 4 4 2 6 5 4 9 6 4 2 # 4 2

PROBENPARTE FÜR  
Ausgabequalität gegenüber Original evtl. gemindert • Evaluation Copy - Quality may be reduced • Carus-Verlag

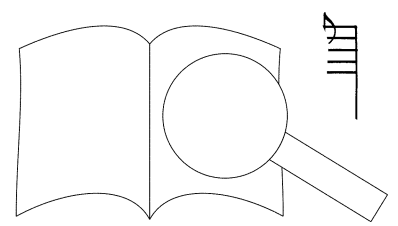

6

*p*

*p*

*p*

Be - glück - te Her - de, Je - su Sch  
 O bless - ed flock, Christ is your s -

*p*

6 6 5 7 4 3 7 1

8

Je - su Scha - fe, die Welt ist euch ein Him - mel - reich, ein  
 st is your shep - herd, the world to you: a heav'n - ly place, a

7 8 7 8 7 8 8 6 6

4 3 4 3 4 3 3 6 6

2 2 2 2 2 2 2 2 2

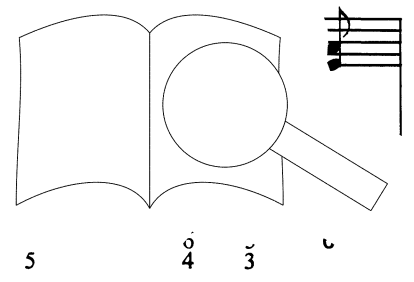

PROBENPARTITUR  
 Ausgabequalität gegenüber Original evtl. gemindert • Evaluation Copy - Quality may be reduced • Carus-Verlag

Him - - mel-reich, die Welt ist euch ein Him - mel-reich, die Welt ;  
 heav'n - ly place, the world to you: a heav'n - ly place, the world'

6 # 6 5 6 8

- reich, be - glück - - - te Her - de, Je - su Scha -  
 place; O bless - - - ed flock, Christ is your shep -

7 # 6 7 6 5 6 9 8 7 5 # 4 2 6

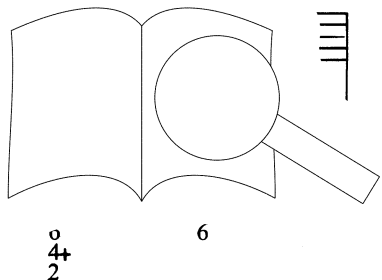

Musical notation for measures 14-15. It features a vocal line and piano accompaniment. The piano part includes a bass line with fingerings 9, 8, 5, 8, 6, 7, 4.

- - - fe, die Welt ist euch ein Him - mel - reich.  
 - - - - herd, the world to you: a heav'n - ly plac~

Musical notation for measures 16-17. It features a vocal line and piano accompaniment. The piano part includes a bass line with fingerings 9, 8, 5, 8, 6, 7, 4.

Musical notation for measures 18-19. It features a vocal line and piano accompaniment. The piano part includes a bass line with fingerings 7, 8, 7, 8, 6, 7, 8, 7, 8, 7, 4, 3, 4, 3, 2, 2.

Ausgabequalität gegenüber Original evtl. gemindert • Evaluation Copy - Quality may be reduced • Carus-Verlag

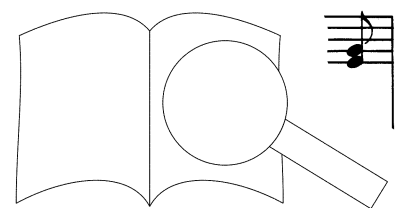



*p*

Be - glück - te Her - de, Je - su Scha  
 O bless - ed flock, Christ is your she

*p*

6 6 5 7 $\sharp$  6 7 $\sharp$

- su Scha - fe, die Welt ist euch ein Him - mel - reich, ein  
 your shep-herd, the world to you: a heav'n-ly place, a

6 5 6 5 6 7 6 6 7 4 5

4 3 4 3 4 4 2 5 4 3

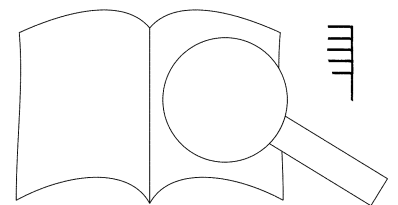

Him - - mel-reich, die Welt ist euch ein Him - mel-reich, die We - st  
 heav'n - ly place, the world to you: a heav'n - ly place, the

6 6h 6 5h 5 6 5 6 5h

mel-reich, be - glück - - - te Her - de, Je - su Scha -  
 ly place, O bless - - - ed flock, Christ is your shep -

7 5 6 5 5 6 9 8 7 5 6 4 2 5h

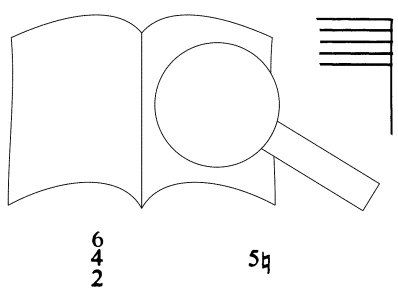

PROBE-PARTITUR  
 Ausgabqualität gegenüber Original evtl. gemindert • Evaluation Copy - Quality may be reduced • Carus-Verlag

27

Musical notation for measures 27-28, including vocal lines and piano accompaniment.

- - - fe, die Welt ist euch ein Him - mel - reich. —  
 - - - herd, the world to you: a heav'n - ly place.

Musical notation for measures 29-30, including piano accompaniment and fingerings (9, 8, 6, 5, 6, 6, 3).

29

Musical notation for measures 31-32, including vocal lines and piano accompaniment.

Musical notation for measures 33-34, including piano accompaniment and fingerings (7/4, 8/3, 7/2, 8/3, 6/4, 6/2, 7/4, 8/3, 7/2, 3, 4/2).

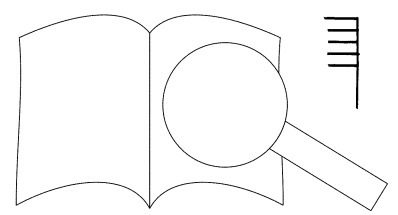

31

Fine

Musical notation for measures 31-32, top system. It consists of three staves: two treble clefs and one bass clef. The music features a melodic line in the upper treble and a supporting line in the lower treble and bass. A dynamic marking 'p' is present at the end of measure 32.

Musical notation for measure 32, middle system. It consists of two staves: one treble clef and one bass clef. The music continues from the previous system.

Musical notation for measures 31-32, bottom system. It consists of two staves: one treble clef and one bass clef. Fingerings are indicated below the notes. A dynamic marking 'p' is present at the end of measure 32. A 'Fine' marking is at the end of the system.

8 5 3    6    6    7 5    5 3    6 4    7 5 3    6 4 2    6

33

Musical notation for measures 33-34, top system. It consists of three staves: two treble clefs and one bass clef. The music continues from the previous system.

Musical notation for measure 34, middle system. It consists of two staves: one treble clef and one bass clef. The music continues from the previous system.

Gü - te schon und hof - - - - - fet  
 here God's grace and hope \_\_\_\_\_ your

Musical notation for measures 33-34, bottom system. It consists of two staves: one treble clef and one bass clef. Fingerings are indicated below the notes.

5    6 4    5    6 4    5    7    5    6 4    5

Musical notation for measure 34, bottom system. It consists of two staves: one treble clef and one bass clef. Fingerings are indicated below the notes.

4    5    5

Musical notation for measures 35 and 36. The system includes a vocal line and piano accompaniment. The key signature has two sharps (F# and C#). The vocal line begins with a rest, followed by notes in measures 35 and 36. The piano accompaniment features chords and moving lines in both hands.

noch des Glau - bens Lohn, und hof - - - - - fet r  
 faith will find re - ward, and hope \_\_\_\_\_ your

Musical notation for measures 35 and 36, showing the piano accompaniment with figured bass. The figures 7, 6, and 7 are visible under the bass line. The piano part includes chords and moving lines in both hands.

Musical notation for measures 37 and 38. The system includes a vocal line and piano accompaniment. The key signature has two sharps. The vocal line begins with a rest, followed by notes in measures 37 and 38. The piano accompaniment features chords and moving lines in both hands.

ei - nem sanf - ten To - - - - -  
 en you have passed through death's \_\_\_\_\_

Musical notation for measures 37 and 38, showing the piano accompaniment with figured bass. The figures 6, 7, 6h, and 6h are visible under the bass line. The piano part includes chords and moving lines in both hands.

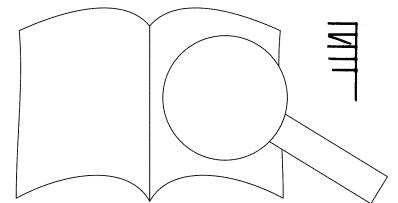

Musical notation for measures 39-40, including vocal line and piano accompaniment. The piano part features chords with fingerings: 7/5, 6/4, 5/#, 5, and 5/6.

- des - schla -  
 - - - - - sweet slum -

Musical notation for measures 41-42, including vocal line and piano accompaniment. The piano part features chords with fingerings: 7/5, 6/4, 5/#, 5, and 5/6.

Musical notation for measures 43-44, including vocal line and piano accompaniment.

u Gü - te schon und hof - - - - - fet  
 y here God's grace and hope \_\_\_\_\_ your

Musical notation for measures 45-46, including vocal line and piano accompaniment. The piano part features chords with fingerings: #, 6/4, 5/#, 6/4, #, #, 6/4, 5/3, 4, 3.

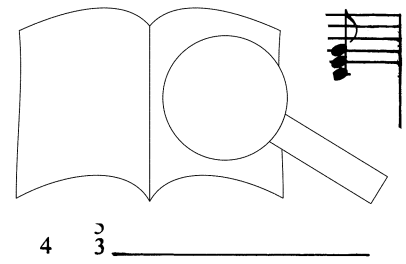

Musical notation for measures 43-44, including vocal staves and piano accompaniment.

noch des Glau - bens Lohn, und hof - - - - - fet noch  
 faith will find re - ward, and hope your fai''

Piano accompaniment for measures 43-44 with chord symbols: 5, 6, #, 6, 5, #.

Musical notation for measures 45-46, including vocal staves and piano accompaniment.

ei - nem sanf - ten To - - - -  
 a you have passed through death's

Piano accompaniment for measures 45-46 with chord symbols: 5, 6, 6b, 6. Includes a magnifying glass icon.

Ausgabequalität gegenüber Original evtl. gemindert • Evaluation Copy - Quality may be reduced • Carus-Verlag

47

des - schla -  
sweet slum -

49

fe, nach ei - nem sanf - ten To - des - schla - fe.  
ber, when you have passed through death's sweet slum - ber.

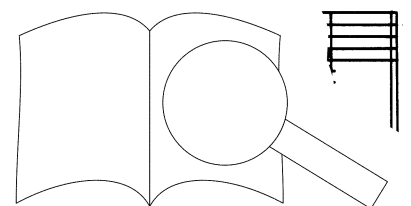

Da



# 6. Choral

Soprano  
Oboe I  
Violino I

Der Herr ist mein ge - treu - er Hirt, dem  
The Lord my faith - ful shep - herd is in

Alto  
Oboe II  
Violino II

Der Herr ist mein ge - treu - er Hirt, dem  
The Lord my faith - ful shep - herd is in

Tenore  
Taille  
Viola

Der Herr ist mein ge - treu - er Hirt, dem  
The Lord my faith - ful shep - herd is in

Basso

Der Herr ist mein ge - treu - er H:  
The Lord my faith - ful shep - herd

Basso continuo

6 5

3  
ich mich ganz ver - trau - e, sein Schäf - lein, führt, auf  
whom I am con - fid - ing. rest in pas - tures green, his

ich mich ganz ver - trau - e, Weid er mich, sein Schäf - lein, führt, auf  
whom I am con - fid - ing. He makes me rest in pas - tures green, his

trau - e, zur Weid er mich, sein Schäf - lein, führt, auf  
fid - ing. He makes me rest in pas - tures green, his

5 7 5 6 6 6 5

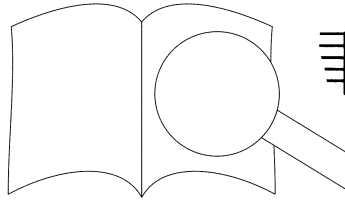

7

schö - ner, grü - nen Au - - - e, zum fri - schen Was - ser leit' er mich, mein  
*sheep he\_ tends with car - - - ing. To liv - ing wa - ters he guides me, my*

schö - ner, grü - nen Au - - - e, zum fri - schen Was - ser leit' er mich, mein  
*sheep he\_ tends with car - - - ing. To liv - ing wa - ters he\_ guides me, my*

8

\_\_\_\_\_ schö - ner, grü - nen Au - e, zum fri - schen Was - ser leit' er mich, mein  
 \_\_\_\_\_ *sheep he tends with car - ing. To liv - ing wa - ters he guides me my*

schö - ner, grü - nen Au - - - e, zum fri - schen Was - ser leit' er mich, mein  
*sheep he\_ tends with car - - - ing. To liv - ing wa - ters*

Taille

6 7 6 6 7 6

11

Seel zu la - ben kräf - tig - - - Wort der Gna - den.  
*soul he strengthens fer - vent lest word of mer - cy.*

Seel zu la - ben se - lig Wort der Gna - den.  
*soul he strengthens y his blest word of mer - cy.*

Seel zu vent - lich durchs se - lig Wort der Gna - den.  
*soul vent - ly by his blest word of mer - cy.*

en kräf - tig - lich durchs se - lig Wort der Gna - den.  
*ens fer - vent - ly by his blest word of mer - cy.*

6 6 5 6 6 6

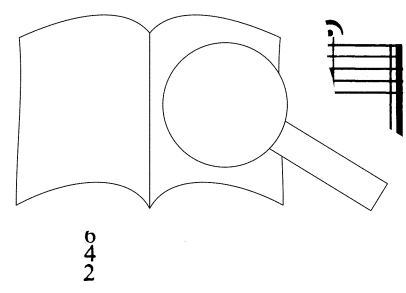

**PROBE-PARTITUR**  
Ausgabequalität gegenüber Original evtl. gemindert • Evaluation Copy - Quality may be reduced • Carus-Verlag 

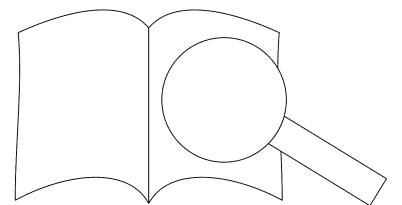

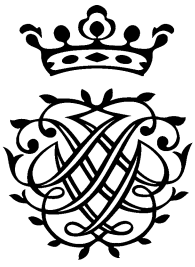

# Bach vocal

## Gesamtedition · Complete Edition

in Zusammenarbeit mit dem Bach-Archiv Leipzig  
In collaboration with the Bach Archive, Leipzig

### Vollständige Ausgabe

Johann Sebastian Bachs gesamte geistliche Vokalmusik liegt bei Carus in modernen, an der historisch informierten Aufführungspraxis orientierten Urtext-Ausgaben samt Aufführungsmaterial vor.

- Vollständiges Aufführungsmaterial zu allen Werken erhältlich: Partitur, Studienpartitur, Klavierauszug, Chorpartitur und Orchesterstimmen
- Bearbeitung der Ausgaben durch international anerkannte Bach-Experten und Interpreten, u. a. Christine Blanker, Pieter Dirksen, Wolfram Enßlin, Andreas Glöckner, Klaus Hofmann, Ulrich Leisinger, Masaaki Suzuki und Peter Wollny
- Jeweils mit einem neuesten Stand
- Innovative practice aids (carus music, the choir app, Carus Choir Coach) und large print editions der wichtigsten Werke erhältlich

Die neue Gesamtedition der Partitur ist hochwertig ausgestattet und rundet das Editionsprojekt Bach ab.

Carus 31.500

### Complete Edition

Johann Sebastian Bach's complete sacred vocal works are published in modern Urtext editions together with performance material geared towards informed performance.

- Complete performance material for all works, including score, study score, and the parts
- Editions edited by international recognized Bach experts and interpreters, including Christine Blanker, Pieter Dirksen, Wolfram Enßlin, Andreas Glöckner, Klaus Hofmann, Ulrich Leisinger, Masaaki Suzuki, Uwe Wolf and Peter Wollny
- Each edition contains a preface reflecting the latest state of Bach research
- Innovative practice aids (carus music, the choir app, Carus Choir Coach) and large print editions of the most important works

A high-quality complete edition in 23 volumes in the Bach vocal edition

Carus 31.500

